

## **NEW DESIGN APPROACHES IN AMBIENT ASSISTED LIVING**

**Ioan Susnea\***

*\* University "Dunarea de Jos" of Galati", Romania, Faculty of Automatic Control, Computer Science, Electrical and Electronics Engineering, Department of Computer and Information Technology*

**Abstract:** After reviewing some of the vast literature related to Ambient Assisted Living (AAL), we noticed that many of the recent solutions in AAL follow the design paradigm defined by the feeding machine presented in the famous Chaplin's movie "Modern Times". Despite all major advances in technology, the assisted person is still an "object", and – in a pure industrial revolution approach - the design focus is on increasing the work productivity of the caregivers. In this brief discussion paper we propose a "third wave" approach on designing AAL systems: rather than creating technology to replace humans in assisting the elderly and disabled people, we should use technology to foster human interactions and enable more caregivers to get involved in this activity. According to this new, prosumerist, paradigm the producers and consumers of care should be able to switch roles. This paper outlines a possible implementation of a simple AAL system based on this paradigm. We also discuss a possible solution for the problem of activity recognition, based on distributed ANNs.

**Keywords:** Ambient Assisted Living, AAL, Ambient Intelligence, Activity Recognition, Distributed ANN

### **1. A WRONG PARADIGM**

As the population in developed countries continues to grow older, a great number of technical solutions attempt to address the increasing demand for medical assistance and home care for the elderly or other persons with various cognitive, sensory, or motor disabilities.

These solutions received different names: Ambient Assisted Living (AAL), Ambient Intelligence (AmI), Home Care Systems (HCS), Smart Homes, Pervasive Healthcare, Telemedicine, e-Health, Smart Environments, etc., but all of them aim "to extend the time people can live in a decent way in their own home by increasing their autonomy and self-confidence, the discharge of monotonously everyday activities, to monitor and care for the elderly or ill person, to enhance the security and to save resources" - Steg et al. (2006).

How efficient are these solutions? Is a multi-million dollar smart home more efficient than a two dollar cane or a pair of crutches in terms of increasing the autonomy and self confidence of the elderly? Do they really reduce the burden of care for the increasing number of patients and the overall economic and social costs of assistance?

In an attempt to answer these questions, we reviewed in part, the vast literature on these topic, including some recently funded AAL research projects listed in Jones et al. (2008), and AALJP (2012).

We noticed that many of the recent solutions in AAL follow the design paradigm defined by the feeding machine presented in the famous Chaplin's movie "Modern Times". Despite all major advances in technology, the assisted person is still an "object", and – in a pure industrial revolution approach - the design focus is on increasing the work productivity of the caregivers.

On the other hand, designing machines capable to replace humans is not an easy task. Thus, some of the existing AAL solutions, though technically feasible, tend to be extremely complex, expensive, and totally impractical.

We also noticed that there is an important neglected resource in AAL: the other people.

Therefore, rather than assuming the simple definition of AAL:

$$AAL = Person\ in\ need + Assistive\ technology$$

we propose a new term in this equation:

$$AAL = person\ in\ need + other\ people + technology$$

In this context, the purpose of the research described in this paper is threefold: (i) emphasize the need for a paradigm shift in the design of AAL systems, (ii) outline a solution to reduce costs of some AAL applications, and (iii) propose the concept of *prosumerism* (Toffler (1981)) in caregiving and outline a possible implementation of such system.

Beyond this introduction, this paper has the following structure:

Section 2 is a brief review of the state of the art in AAL and related fields, aimed to identify the current major design approaches in AAL

Section 3 proposes a simple solution for the problem of activity recognition in Ambient Intelligence systems, based on distributed neural networks, with the aim to reduce costs and improve reproducibility of such systems.

Section 4 proposes a new paradigm in designing AAL systems, and outlines the structure of a system built according to this new paradigm.

Section 5 is reserved for conclusions

## 2. CURRENT DESIGN APPROACHES IN AAL

There is a significant amount of fuzziness in what concerns the definitions and the boundaries of the AAL related domains (see figure 1 for an illustration of how these domains are overlapping).

It is not the objective of this paper to provide a detailed description of the main concepts and a comparison between various AAL related domains. This information is available in some comprehensive surveys (see Nak-Young (2011), Koch (2006), Röcker (2011), Cook (2009), Orwat (2008), Acharyya (2008) and Aztiria (2010)).

We will only note here that Home Care Systems (HCS) are an extension of the "classic" home automation systems, telemedicine focuses on

monitoring biomedical parameters and on ICT based communication between the patients and professional healthcare personnel, AAL extends the domain of interest beyond the boundaries of a home, and Ambient Intelligence (AmI) attempts to overcome the drawbacks of all the other systems by creating complex, adaptive, context aware and predictive systems.

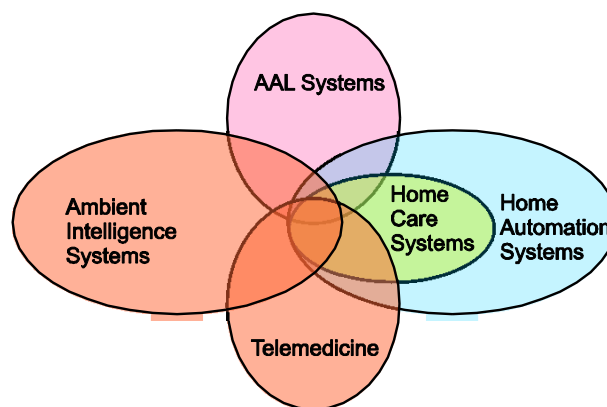

Fig.1. Overlapping domain boundaries for AAL and related domains

For a better understanding of the differences between these approaches, consider the example of designing a "smart" coffeemaker.

In a HCS approach, the smart coffeemaker will have a programmable timer to deliver coffee at a specified time of the day, and probably a remote control unit.

The AAL design will improve the Human Computer Interface (HCI) by adding a speech recognition and synthesis module, and will use special actuators to deliver the coffee depending on the specific disabilities of the assisted person.

The telemedicine solution will record the total amount of coffee requested by the user, will monitor his blood pressure, will issue warnings or alarms if this is too high, and will report everything to the doctor via the Internet, along with some pulse rate histograms.

Finally, the AmI solution will try to anticipate the need for coffee of the user by tracking his activity over time in order to extract activity patterns, will recognize the context, and will use a humanoid robot to deliver tea instead of coffee. Optionally, the robot will generate wise sentences about a healthy lifestyle.

Sounds hilarious, but this is a pretty accurate description of the main approaches in designing smart devices and smart environments (see references Becker (2006), Nak-Young (2011), Koch (2006), Röcker (2011), Cook (2009), Orwat (2008), Acharyya (2008), and Aztiria (2010)).

Becker et al. in Becker (2006) identify a list of shortcomings of the HCS related solutions. Among them, we cite:

- Too much focus on technology, and the tendency to treat the assisted person as an object;
- Health assistance solutions are too socially visible and tend to emphasize the assisted person's disabilities, acting as a social stigma, and leading to low acceptance of the entire solution;
- Body mounted sensors are often obtrusive and tend to hinder the user's normal activity;
- Most existing solutions rely on a single modality for sensing, which leads to a limited view on the current situation, thus offering low quality and restricted assistance;
- In many situations, special skills are required to program and operate the system. This is particularly difficult for elderly and disabled users;
- Most existing solutions propose systems that are not aware of the user's context.

The AmI design approach solves most of the above mentioned shortcomings (Cook (2009), Aztiria (2010)), but the resulting solutions are unrealistic in terms of complexity, cost, time to market, and reproducibility.

It appears that none of the current design approaches is entirely capable to create low cost, efficient AAL applications. In the next sections, we outline two possible solutions to this problem.

### 3. DISTRIBUTED ANN FOR ACTIVITY RECOGNITION IN LOW-COST AMI APPLICATIONS

According to Aztiria (2010), the general structure of an AmI system has the general structure shown in figure 2.

In this structure, a key element in the machine reasoning layer is the activity recognition module. A review of the current methods and algorithms for activity recognition is available in Hein (2008). Among them, Artificial Neural Network (ANN) based solutions are pretty common (see Rivera-Illingworth (2005), and Machado (2008)).

In this section, we present a solution based on low cost sensors (PIR motion detectors and RFID) to a problem formulated by Cook et al. in Cook (2009): detect and prevent possible hazardous situations at home. They describe a scenario in which the user (e.g. a person with cognitive impairment) turns the

cooker on and leaves it unattended for more than a specified time (see figure 3).

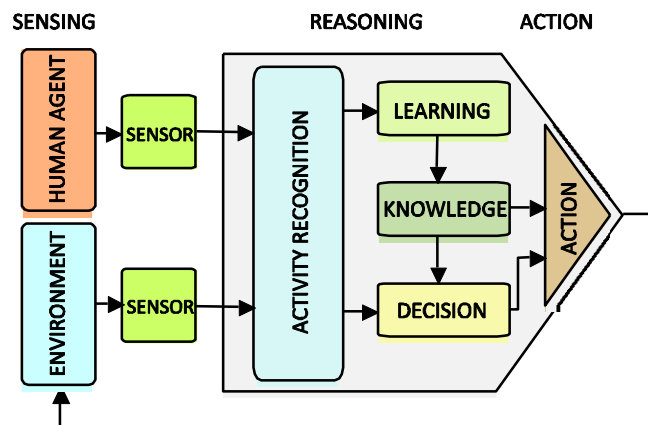

Fig.2. General structure of an AmI system according to Aztiria (2010)

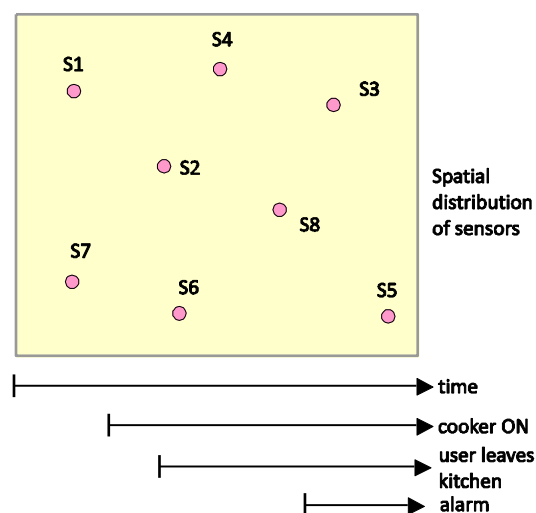

Fig.3. Detecting hazards at home – problem formulation

The AAL system should be able to detect such potentially dangerous situations, and to issue warnings or alarms.

Obviously, the problem is relatively simple, and can be solved in the "classic" home automation/home care systems approach, by using a PLC or other control unit (see figure 4).

The solution outlined in figure 4, and any other solution based on a centralized approach have little practical utility, because real life AAL applications are far more complex than detecting hazards in the kitchen. Solving all the problems with a single program may be challenging, and the resulting program will be very so tightly connected to a specific home, a specific patient, and a specific set of sensors, that it will be virtually impossible to

reproduce.

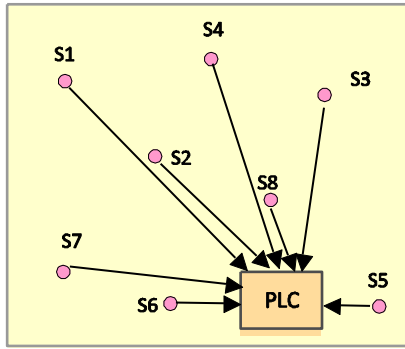

Fig.4. Detecting hazards at home – Home automation solution

In a recent study (Susnea (2012)), we proposed a method to design “detachable neurons” with low-cost microcontrollers. Such neurons are implemented on the nodes of a communication network, and the synapses between them are defined in the process of communication.

In this approach, for any three layer perceptron it is always possible to design an equivalent distributed ANN.

With the notations in figure 5,  $A_i$  is the weighted sum of the inputs  $x_{ij}$ :

$$(1) \quad A_i = \sum_{j=1}^N w_{ij} x_j$$

and the output  $y_i = f(A_i)$  is usually a sigmoid function:

$$(2) \quad y_j = \frac{1}{1 + e^{-\sum_{j=1}^N w_{ij} x_j}}$$

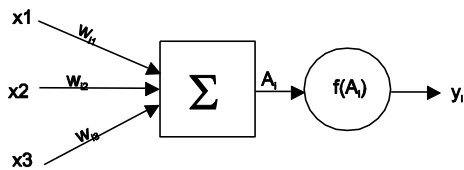

Fig.5. Structure of a generic artificial neuron

Assuming that:

- each neuron has an unique ID on the network,
- each neuron holds a list containing the IDs of the neurons with whom it makes synapses,
- each neuron stores the weights  $w$  of the incoming synapses,
- each neuron is capable to compute the values  $A$  and  $y$ , according to (1) and (2),
- each neuron broadcasts messages containing the current computed value of its output  $y$ ,

it results that the problem of implementing such a neuron can be solved by creating and maintaining a data structure as follows:

```
struct neuron
{
    double  $\bar{x}$  [LAYER_SIZE];
    double  $\bar{w}$  [LAYER_SIZE];
    double A;
    double y;
}
```

where  $\bar{x}$  is the vector containing the input values,  $\bar{w}$  is a vector containing the weights of the incoming synapses (stored locally),  $A$  is computed locally according to (1), and  $y$  is the output value, computed locally with (2).

In a feedforward topology, the vector  $\bar{x}$  contains the output values of the neurons of the previous layer. Obviously, these values can be transmitted either by direct connections between neurons, as depicted in figure 1, or by means of messages, broadcasted over a communication network.

Figure 6 shows how the computing and communication tasks are distributed over the nodes of the network.

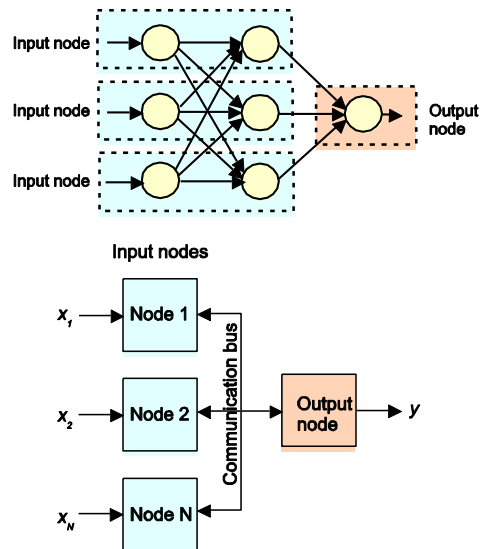

Fig.6. Implementing detachable neurons in the nodes of a communication network

Since the distributed ANN (DANN) built this way is entirely equivalent with the perceptron model, it results that both distributed and non-distributed implementations of this model can use the same set of synapse weights, adjusted in a process of learning. So, the DANN can simply borrow the knowledge

acquired by an equivalent non-distributed implementation using a recorded dataset. (Note that training data can be artificially generated using fuzzy rules.) This can be done by broadcasting the weights of the synapses over the communication network, and instructing the detached neurons to identify and store the weights of their own incoming synapses.

It is also relatively easy to implement the backpropagation learning algorithm on a DANN (Susnea (2012)).

Returning to the problem of detecting hazards at home, the solution based on DANN requires detachable neurons attached to every sensor node (SN) and a special output node (ON) attached to an actuator (e.g. a speech synthesizer) to generate warnings or alarms (see figure 6).

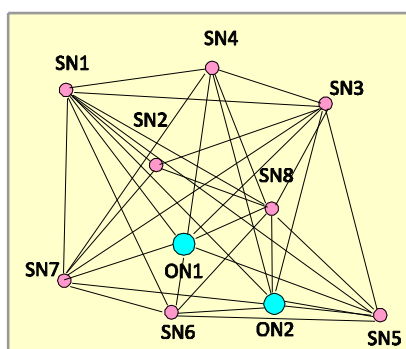

Fig.7. Detecting hazards at home – DANN solution

Note that in this structure it is possible to add more output nodes to control, for example, the lighting (Machado (2008)), or the heating system of the building (Susnea (2012)).

Compared to other activity recognition algorithms (see Munguia (2004)), the solution based on DANN has some important advantages:

- The detachable neurons can be designed as identical, interchangeable, lightweight hardware modules, based on low cost microcontrollers, and including existing wireless communication interfaces;
- Such modules can interface virtually any type of sensor;
- The network can be configured to execute multiple functions by including additional output nodes;
- No central processing unit and no special software are required;

As a result, the overall development costs of the some AAL application can be significantly reduced. Further research to investigate other network topologies that allow unsupervised learning algorithms may be beneficial.

#### 4. TOWARDS A SOCIAL NETWORK FOR CARE

There are a few situations when machines perform better than humans. Industrial robots can endlessly repeat monotonous tasks, unmanned vehicles fly over enemy territory, or dive into the ocean, robots detect mines in mined fields, etc.

Unfortunately, there is no machine capable to wash or dress a person immobilized by illness or disability, and is very unlikely that such machine will be ever produced. For this kind of tasks we will always need humans. And it's not an easy job. Numerous studies (Covinsky (2003), Livingston (1996), Given (1998)) demonstrate that caregivers face a higher risk of depression, and other severe health problems. With one very notable exception: volunteers live longer (Konrath (2012)).

So, the idea of finding the technological means to involve more volunteers in caregiving is, at a first glance, interesting.

But the motivations for volunteering and other altruistic behavior are complex and individual (Fehr (2003), Batson (1990), Gallese (2001), Oded (2007)). A surprising study (Frey (1999)) demonstrates that financial rewards are likely to determine volunteers to *work less*.

Regardless of any formal definition of altruism, in some cases *altruism is a postponed egoism*. Most people voluntarily give up a share of their monthly income to contribute to a pension plan. Their money actually go to support other people, already retired. This is not altruism: that people hope – and strongly believe - that they will receive the same treatment when they retire. The pension system is proven to work pretty well for many years – so, why not create a similar system for caregiving, a sort of “mutual fund of good deeds” that would enable the users with a record of volunteering to receive free services of care when they need them ?

The tremendous success of the existing social networks (Facebook, LinkedIn, Twitter, etc.), which have hundreds of millions of users, seems to demonstrate that, at least from a technical perspective, such system is feasible.

In fact, the idea of using ICT in AAL is not new. In an article entitled “The goal: smart people, not smart homes” (Intile (2006)), the MIT researcher Stephen Intile describes a facility (PlaceLab) that uses ubiquitous computing and “sensor-driven health applications for motivating (but *not* controlling!) health related behavior”.

Passas et al. in Passa (2009) describe the project PeerAssist, which aims to develop a ICT platform to facilitate contacts between caregivers and assisted people.

Cesta et al. in Cesta (2009) describe ExCITE (Enabling SoCial Interaction Through Embodiment) – another EU funded project that combines telepresence and a mobile robot to allow the users not only to virtually visit each other, but also to navigate in the peer's environment.

As opposed to all of the above solutions, we propose a *prosumerist approach* (Toffler (1981)) on caregiving, wherein producers and consumers of care may switch roles.

For example, a person suffering from a mild, incipient form of a chronic disease is aware of the fact that he will need assistance himself within a certain time horizon. Knowing that he will be entitled to receive care, free of charge, if he dedicates some of his time to helping others, it is very likely that he will voluntarily join a group established according to these rules.

In many other cases, it is even possible to predict, based on medical, social and family records, that a certain person has a higher risk of contracting a debilitating disease. For such a person, participating in a system that guarantees reciprocity will act like an insurance policy.

What we propose is a system that works by allowing direct interaction between careseekers and caregivers, with minimal supervision and costs. This is possible with the following technical setup:

- Create an Internet based platform, to manage and display the requests for assistance from various sources (SMS, MMS, email, web).
- Create a database of caregivers, and keep track of their activity, by allowing them, after a registration, to select from the current list of active requests for assistance. Let them work Wiki-style, when they choose, what they choose, but keep a record of the total time they spend in caregiving activities.
- Allow direct communication between careseekers (or their families) and caregivers (Skype, mobile, email, IP cameras when possible). Enable telepresence when possible.
- Create a system for reputation management based on user feedback (ebay style) for both careseekers and caregivers, so that any user can access a "profile" of the persons with whom he comes in contact, and provide feedback after the actual contact.

Note that, once created, the system described above will require minimal costs for maintenance. After some time, the right to register as a careseeker in the system can be restricted only to former caregivers. Careseekers without a previous record as caregivers

may be required to pay a fee in order to benefit from the services offered by the system.

In principle, such a system can be maintained by NGOs or Government authorities.

Several similar systems can operate in parallel.

Most of software modules involved are open source

## 5. CONCLUSIONS

In this paper we argue that the research in AAL is following a wrong paradigm: instead of creating technology to replace humans in assisting the elderly and disabled people, we should use technology to foster human interactions and enable more caregivers to get involved in this activity.

We proposed a new paradigm based on a prosumerist approach, wherein producers and consumers of care may switch roles, and we outlined an example of system designed according to this new paradigm.

We also described a method to solve the problem of activity recognition using low cost sensors and distributed neural networks.

## 6. REFERENCES

- AALJP - Ambient Assisted Living Joint Programme ongoing projects listed at: <http://www.aal-europe.eu/projects/Ongoing%20Projects>
- Acharyya, A., Maharatna, K., Al-Hashimi, (2008), "Hardware development for pervasive healthcare systems: Current status and future directions", in *APCCAS 2008. IEEE Asia Pacific Conference on Circuits and Systems, 2008*.
- Aztiria A., Izaguirre A., Augusto J.C. (2010), "Learning patterns in ambient intelligence environments: a survey", in *Artif Intell Rev* (2010) 34:35–51
- Batson, C. D. (1990), "How social an animal? The human capacity for caring." *American Psychologist, Vol 45(3), Mar 1990, 336-346*
- Becker, M., Werkman E. (2006), et. al., *Approaching Ambient Intelligent Home Care Systems, Pervasive Health Conference and Workshops, 2006, pp. 1 - 10*
- Cesta A., et al. (2012) "Addressing the Long-Term Evaluation of a Telepresence Robot for the Elderly". In *Proceedings of ICAART'12, the 4th Int. Conf. on Agents and Artificial Intelligence, Special Session on Intelligent Robotics Vilamoura, Algarve, Portugal, February 6-8, 2012*

- Cook D.J., Augusto J.C. (2009) , and Jakkula V.R., "Ambient Intelligence: Technologies, Applications, and Opportunities", *Pervasive and Mobile Computing Volume 5, Issue 4, August 2009, Pages 277–298*
- Covinsky K.E. , et. al. (2003) "Patient and Caregiver Characteristics Associated with Depression in Caregivers of Patients with Dementia", *J Gen Intern Med. 2003 December; 18(12): 1006–1014.*
- Fehr E. and Fischbacher U. (2003), "The nature of human altruism", *Nature 425, Oct. 2003, pp.785-791*
- Frey B. and Götte L. (1999) ("Does Pay Motivate Volunteers?" *Institute for Empirical Economic Research, University of Zurich, Working Paper 7, 1999*
- Gallese V., The 'Shared Manifold' Hypothesis From Mirror Neurons To Empathy, *Journal of Consciousness Studies, 8, No. 5–7, 2001, pp. 33–50*
- Given B, King S, Collins C, Given C. (1998) "Family caregivers of the elderly: involvement and reactions to care". *Archives of Psychiatric Nursing. 1988;2:281–288.*
- Hein A., Kirste T.,(2008) "Activity Recognition for Ambient Assisted Living: Potential and Challenges", *Ambient Assisted Living - AAL - 1. Deutscher AAL-Kongress mit Ausstellung / Technologien - Anwendungen – Management, Berlin, Germany, 2008*
- Intille S. (2006) "The goal: smart people, not smart homes". In *Proceedings of the International Conference on Smart Homes and Health Telematics*, pages 3–6, Belfast, United Kingdom, 2006.
- Jones B. and Hayden J. (2008), *Innovation in an Age-Integrated Society* INNOGrips third Innovation Policy Workshop, Brussels, 18-19 December 2008
- Koch S., (2006) "Home telehealth - Current state and future trends", *International Journal of Medical Informatics (2006) 75, 565–576*
- Konrath S. et al. (2012), "Motives for Volunteering Are Associated With Mortality Risk in Older Adults", *Health Psychology, 2012, Vol. 31, No. 1, 87–96*
- Livingston G, Manela M, Katona C. (1996) "Depression and other psychiatric morbidity in carers of elderly people living at home." *BMJ. 1996;312:153–6*
- Machado C. and Mendes J.A. (2008), "Automatic Light Control in Domotics using Artificial Neural Networks", *World Academy of Science, Engineering and Technology 44, 2008*
- Munguia T., Intille E., Larson, K. (2004): "Activity recognition in the home using simple and ubiquitous sensors". In: Ferscha, A., Mattern, F. (eds.) *PERVASIVE 2004. LNCS, vol. 3001, pp. 158–175.* Springer, Heidelberg (2004)
- Nak-Young C., Mastrogiovanni F. (2011) "*Handbook of Research on Ambient Intelligence and Smart Environments: Trends and Perspective*", *Information Science Reference, (2011) ISBN 978-1-61692-857-5*
- Oded N. (2007) , "What motivates Wikipedians?" *Communications of the ACM Volume 50 Issue 11, November 2007*
- Orwat C., Graefe A. and Faulwasser T. (2008), "Towards pervasive computing in health care – A literature review", *BMC Med Inform Decis Mak. 2008;8:26*
- Passas N. et al. (2009) "ICT for the elderly people - Existing schemes and future perspectives" Deliverable D2.1, Project AAL-2009-2-137, [http://www.cnl.di.uoa.gr/peerassist/Deliverables/d\\_2\\_1\\_schemes\\_perspectives.pdf](http://www.cnl.di.uoa.gr/peerassist/Deliverables/d_2_1_schemes_perspectives.pdf)
- Rivera-illingworth F., Callaghan V., Hagrais H. (2005), "A Neural Network Agent Based Approach to Activity Detection in AmI Environments", In the IEEE International Workshop, *Intelligent Environments 2005 (IE05)*, Colchester, UK, 28-29th June 2005
- Röcker K., (2011) "Designing Ambient Assisted Living Applications: An Overview over State-of-the-Art Implementation Concepts", 2011 *International Conference on Modeling, Simulation and Control IPCSIT vol.10 (2011)*
- Steg, H., Strese, H., Loroff, C., Hull, J. & Schmidt, S. (2006). *Europe Is Facing a Demographic Challenge - Ambient Assisted Living Offers Solutions.* Berlin, Germany: VDI/VDE/IT
- Susnea I. (2012) "Distributed Neural Networks - Microcontroller Implementation and Applications" *Studies in Informatics and Control, Vol. 21, Issue 2, June 2012*
- Toffler A., (1981), *The Third Wave*, London, Pan Books Ltd, 1981