



UNIUNEA EUROPEANĂ

GUVERNUL ROMÂNIEI

Fondul Social European
POSDRU 2007-2013

Instrumente Structurale
2007-2013

CIOSDRU

Universitatea Politehnica
din București

FONDUL SOCIAL EUROPEAN

Investește în oameni

Programul Operațional Sectorial pentru Dezvoltarea Resurselor Umane 2007-2013

Proiect POSDRU/159/1.5/s/132397 – Excelență în cercetare prin burse doctorale și postdoctorale - ExcelDOC

Universitatea “Dunărea de Jos” din Galați

Școala doctorală de Inginerie



ABSTRACT

STUDIES ON NONCIRCULAR GEARS DESIGN AND GENERATION

Doctorand

ing. Cristescu Bogdan

Conducător științific:

Președinte Comisie:

Referenți științifici:

Prof.dr.ing. Andrei Laurenția

Prof.dr.ing. Scutelnicu Elena

Prof.dr.ing. Cănanău Sorin

Prof.dr.ing. Dodun Oana

Prof.dr.ing. Rîpă Minodora

Universitatea “Dunărea de Jos” din Galați

Universitatea “Dunărea de Jos” din Galați

Universitatea Politehnică din București

Universitatea Tehnică „Gheorghe Asachi” din Iași

Universitatea “Dunărea de Jos” din Galați

Seria I4: Inginerie industrială, Nr. 37

Galați

2016

Seriile tezelor de doctorat sustinute public în UDJG

începând cu 1 octombrie 2013 sunt:

Domeniul ȘTIINȚE INGINEREȘTI

Seria I 1: Biotehnologii

Seria I 2: Calculatoare și tehnologia informației

Seria I 3: Inginerie electrică

Seria I 4: Inginerie industrială

Seria I 5: Ingineria materialelor

Seria I 6: Inginerie mecanică

Seria I 7: Ingineria produselor alimentare

Seria I 8: Ingineria sistemelor

Domeniul ȘTIINȚE ECONOMICE

Seria E 1: Economie

Seria E 2: Management

Domeniul ȘTIINȚE UMANISTE

Seria U 1: Filologie- Engleză

Seria U 2: Filologie- Română

Seria U 3: Istorie

FOREWORD

Noncircular gears are an ongoing challenge for gear industry specialists, interested by the development of modern techniques and easy processing and the introduction of these complex machine parts in as many fields as alternative to the classical mechanisms. Based on knowledge from various fields: machine parts, mechanisms, computer graphics and computer-aided design, field researches are supported by advanced software and unconventional methods of processing, so that studies become more complex and detailed, aiming to improve performance circular gears.

This paper presents an original method of generalization the generation of noncircular gears teeth process. Research conducted at the Faculty of Engineering of the University "Dunărea de Jos" Galați, with the current state support in the field, through the traditional stages in an original way, using specific codes and interference multiple programming environments, drawing and processing. The obtained results constitute a significant contribution in the field of transmission gears with variable motion.

The author expresses gratitude to the scientific coordinator, Prof. Laurenția Andrei for her constant support and confidence in solving problems and developing research thesis. Explanations and suggestions offered were helpful in setting and achieving the objectives of the thesis.

Thanks are addressed to Prof. Domenico Mundo and Prof. Guido Danielli, Department of Mechanical Engineering of the University of Calabria, for their support during the three months of mobility.

Also, the author addresses thanks to members of the mentoring work of doctoral internship, Prof. Catalin Fetecău, Prof. Minodora Ripa and Prof. Gabriel Andrei, who by constant participation and constructive comments, contributed to completing the internship.

Team management and project implementation POSDRU/159/1.5/S/132397 are thanked them for their support.

Lastly, the author expresses gratitude and thanks addressed to family and close ones to trust, understanding and support they have shown.

Galați, July 2016

Bogdan Cristescu

TABLE OF CONTENTS

Introduction	15
List of figures	21
List of tables	26
1. STATE OF ART	27
1.1. Introduction	29
1.2. Types of noncircular gears	31
1.3. Industrial applications for noncircular gears	33
1.4. Noncircular gears design	38
1.4.1. Noncircular pitch curves design	38
1.4.2. Generation of noncircular gears teeth	44
1.4.3. Manufacturing of noncircular gears	51
1.5. Conclusions	52
2. HYPOTHESIS FOR NONCIRCULAR CENTRODES DESIGN	55
2.1. Introduction	57
2.2. Hypothesis of the variation law for the transmission ratio	60
2.3. Hypothesis of the driving centrode geometry	65
2.4. Hypothesis of the driven centrode kinematics	70
2.5. Conclusions	72
3. NONCIRCULAR GEARS TEETH GENERATION	75
3.1. Introduction	77
3.2. Noncircular gears base curve	78
3.2.1. Hypothesis CB1 for the base curve	79
3.2.2. Hypothesis CB2 for the base curve.....	81
3.3. Kinematic generation of the teeth flanks profiles	83
3.3.1. Correct kinematic generation of the teeth flanks profiles	84
3.3.2. Approximate kinematic generation of the teeth flanks profiles.....	90
3.3.3. Comparision between teeth flanks profiles	95
3.3.4. Solid mideling of noncircular gears	99
3.4. Processing noncircular gears	100
3.5. Conclusions	101

4. NONCIRCULAR GEARS PERFORMANCES ANALYSIS	103
4.1. Introduction	103
4.2. Static analysis of noncircular gears engagement performances	106
4.2.1. Gear tooth contact pattern analysis.....	106
4.2.2. State of stress and stain	114
4.3. Dynamic analysis of noncircular gears engagement performances.....	123
4.3.1. Dynamic simulation	123
4.3.2. Generation hypothesis influence on engagement performances...	127
4.3.3. Pressure angle influence on engagement performances	129
4.4. Conclusions	132
5. CONCLUSIONS AND PERSONAL CONTRIBUTIONS	133
5.1. Conclusions	135
5.2. Personal contributions	137
LIST OF PAPERS	139
REFERENCES	141

INTRODUCTION

With complex kinematic and geometric characteristics and providing important benefits (reliability, high power transmission, tolerance to overload), noncircular gears constituted a permanent challenge for scientists and due to modeling and simulation software development, they were relaunched in the industry as alternatives to conventional mechanisms. At the same time, new processing methods using advanced and unconventional technologies provoked deepen studies and allowed the development of new approaches in the design of noncircular gears, so currently noncircular gearing can be found in many industrial applications (hydraulic industry, agriculture, electronics, robotics, auto industry, etc.).

TESIS OBJECTIVES

Design of noncircular gears is unstandardized process, but there are two main stages to be covered: noncircular centrodes modeling and teeth generation. The review of literature revealed the existence of specific methods approached by specialists for noncircular centrodes modeling and, accordingly, different approaches to generate teeth which, unlike the circular gears teeth with standardized elements, exhibit variable geometry from one tooth to another and, also, for the flanks of the same tooth.

This paper aims to generalize the procedure of generating noncircular gears teeth and the developed study involves the following steps:

1. Modeling circular centrodes using three hypotheses: (i) the assumption of defining the law of variation of transmission ratio, (ii) defining the geometry of leading centrode, (iii) the assumption defining the law of motion of the driven element.

Modeling noncircular centrodes represents the first step in designing noncircular gears. Kinematic and geometric features specific to each pair of conjugated centrodes are produced using original codes PHP / MySQL that provide both graphics and a database to be used during the study developed later. It is also created an interactive platform that allows the modeling of noncircular centrodes, based on the initial design data specific to each of the three hypotheses.

2. Noncircular gears teeth generation using materialized generator.

Based on specific elements of circular gears, is developed a study regarding the possibility of generating noncircular gears teeth using materialized generator which requires the knowledge of the base curve. The noncircular base curve is determined based on two assumptions: (i) the radius vector is perpendicular to the line of engagement and (ii) a constant radius of curvature of the tooth flank. Original PHP / MySQL codes are created providing the data necessary for the study (graphic data, numerical data).

3. Noncircular gears teeth generation using the pitch curve and the pressure and angle.

Generalizing the process of noncircular gears teeth generation is analyzed using two original methods: (i) hypothesis 1 (IpGC1) considers the generation of cinematic accurate tooth flank profile, considering, at runtime, the pitch line of the rack cutter tangent to the noncircular pitch curve, permanently changing its orientation. Whatever the noncircular pitch curve geometry is, with convex-concave zones, the profile of the tooth flank generated called GCP (generated cinematic precise), is a certain curve; (ii) hypothesis 2 (IpC2) takes into account

the "approximate" cinematic generation of the profile flank of the tooth, absorbing the noncircular pitch curve, in the vicinity of the current point, with the arc of a circle "equivalent" having a radius equal to the radius of curvature of the pitch curve in that point. The generated tooth flank profile, called GCA (cinematic generated approximately) is an involute corresponding to the equivalent circle. Algorithms are proposed for the two hypotheses underlying the original PHP codes that allow graphical representation of tooth flanks.

4. *Noncircular gears manufacturing.*

Based on data provided by the original codes created for teeth generation, virtual models of the noncircular gears are edited in AutoCAD and then used in the manufacturing process. An unconventional manufacturing method is proposed using 3D printer Prusa I3-2. A trial stand equipped with "step by step motor" and programmable Arduino Uno circuit for noncircular gears testing is created.

5. *Noncircular gears engagement conditions analysis.*

Unlike circular gears meshing with performances analyzed by standard methods, noncircular gears require special procedures of studying the conditions of engagement and these are virtual solid model based methods. This paper presents original meshing analysis procedures which provide quantitative and qualitative data regarding the path of contact and also, data regarding the state of stress and strain in conditions to highlight the influence of the working hypothesis and of the pressure angle value. Static contact between teeth is analyzed in AutoCAD using solid models of noncircular gears based on an algorithm involving a controlled initial interference. For the state of stress and strain are carried out two studies by finite element method on the solid models imported from AutoCAD in INVENTOR: a static analysis and a dynamic analysis, which simulates engagement and loading in certain areas of noncircular gears.

THESIS STRUCTURE

The thesis is structured to meet the objectives of the proposed research: the study of the field research - modeling of noncircular centrodes – teeth generation and prototypes manufacturing – analysis of noncircular gears meshing. Investigations are presented during 5 chapters as follows:

Chapter 1 provides an overview of the specific theoretical elements for noncircular gears and their applications in various fields, the generation and manufacturing of the noncircular gears proposed by the researchers. On the analysis of the field research is based the proposed study in later chapters with regard to the teeth generation for noncircular gears and analysis of the meshing conditions.

Chapter 2 develops the first stage of non-circular gears design, modeling centrodes respectively. Original PHP / MySQL codes are created that provides both graphical representations of centrodes and the variation of the gear ratio and databases that contain specific geometric and kinematic characteristics of the designed gear. An original approach is presented based on an interactive platform that synthesizes the three hypothesis for noncircular mating centrodes modeling: (1) the assumption of the variation law for the gear ratio, (2) the assumption of the driving centrode geometry and (3) the assumption of the variation law for the driven element.

Chapter 3 proposes a comprehensive study on generalization of the teeth generating process for noncircular gears. From data provided by circular gears theory, first is analyzed the possibility of teeth generating using materialized generator or base curve. Two assumptions are being developed for the determination of the base curve (i) the radius vector is perpendicular to the line of engagement and (ii) a constant radius of curvature of the tooth flank. Original PHP / MySQL codes provides the necessary data for the study (graphic data, numerical data), and it is observed that in both cases, the geometry of the base curve presents corner and return points with increased concave areas, and therefore is not adequate for teeth generation. This observation eliminates materialized generator method from the generalization process of noncircular teeth flanks modeling.

The teeth generating is further approached based on pitch curve and using specific elements of rolling without slipping. Two hypotheses are proposed: (i) hypothesis 1 (IpGC1), the cinematic generation of accurate profile flank tooth, considering that the pitch line of rackcutter is tangent to the noncircular pitch curve and their orientation constantly changes and (ii) hypothesis 2 (IpC2), the cinematic generation of "approximate" profile flank tooth assimilating the noncircular pitch curve, in the vicinity of the current point, with the arc of a 'equivalent' circle with radius equal to the radius of curvature of the noncircular curve in the division point. Original PHP / MySQL codes are created to get graphic representations of the tooth flanks. Also, the databases provided are imported in AutoCAD for processing and editing of solid models of noncircular gears.

An unconventional method of manufacturing is proposed using 3D printer Prusa I3 - 2, based on solid models obtained in AutoCAD. The noncircular gears so processed are used to create a trial stand for testing.

Chapter 4 evaluates the performance of noncircular gears meshing, aiming the influence of the design hypothesis and the value of pressure angle. Static contact characteristics between conjugated teeth and the state of stress and strain are analyzed. Parameters defining the contact between teeth are quantitative - surface of the contact pattern and qualitative - number of pairs of teeth meshing and are evaluated in AutoCAD, based on an algorithm that uses a controlled initial interference. The state of stress and strain is analyzed in INVENTOR, by finite element method, both in static and dynamic conditions. The analysis is performed on the teeth located in concave, convex and quasi straight areas.

Chapter 5 highlights conclusions on the whole research and personal contributions in the generalization process of generating circular gears teeth.

CAP.1. STATE OF ART

1.1. INTRODUCTION

Noncircular gears are machine parts that can ensure atypical movements, characterized by complex geometric features and variable kinematic characteristics. Benefits that present the main argument is that the noncircular gears in their use as a substitute for traditional mechanisms (cams, clutches, transmissions with chains or straps) that can generate similar movements. Thus, non-circular gears present a compact, precise, reliable and superior characteristics on mechanical strength and tolerance to overload. The major drawback, derived from the complexity of these geometric and kinematic gearing leading to lack of standardized methods of generation, is the high cost of processing. Currently, due to the continuous improvement of technologies for generating and processing, as well as the steady growth of interest in non-circular gears, the production cost was reduced significantly ([1], [2]).

Noncircular gears have intrigued scientists since sec. XV, when the first mentions are dated represented several drawings signed by Leonardo da Vinci in the collection "Codex " (Fig.1.1) [3], [4]. In the centuries that followed, noncircular gears acquire particular applications. Thus, astronomical instruments, musical clock or toys mechanisms are built using non-circular gear (sec. XVII - XVIII) [5].

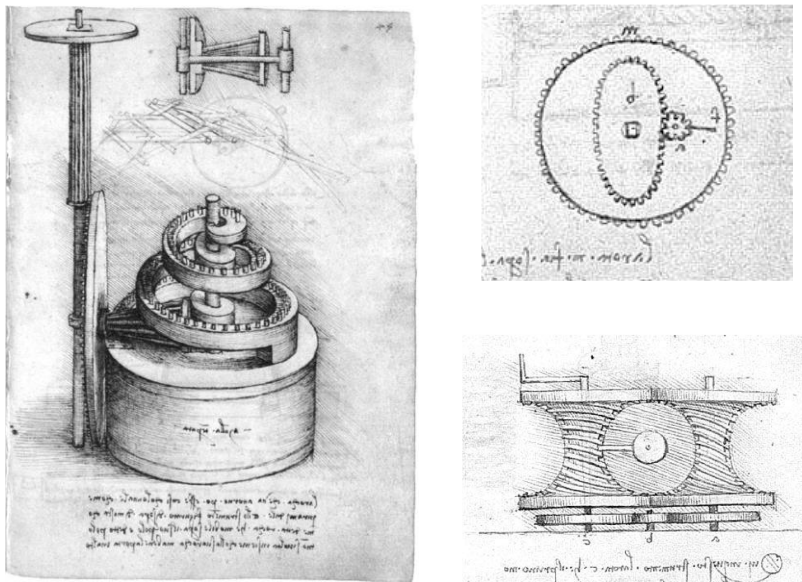

Fig.1.1. Noncircular gears sketched by Leonardo da Vinci in the collection "Codex" [3], [4]

In the ninth century circular gears are placed in the educational process by scientist Ferdinand Redtenbacher and late nineteenth and early twentieth century is the period in which they are made strides in research of noncircular gears.

1.2. TYPES OF NONCIRCULAR GEARS



Fig. 1.4. **Noncircular gears with continuous variable speed**
 a) elliptical gears [20]; b) four lobes noncircular gears [21]

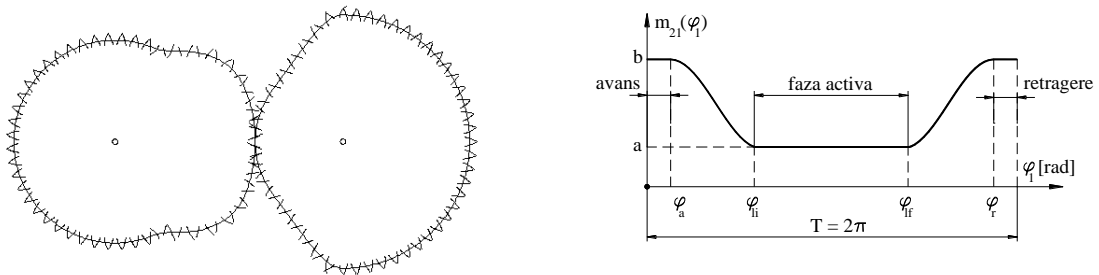

Fig. 1.5. **Multispeed gears** [2]

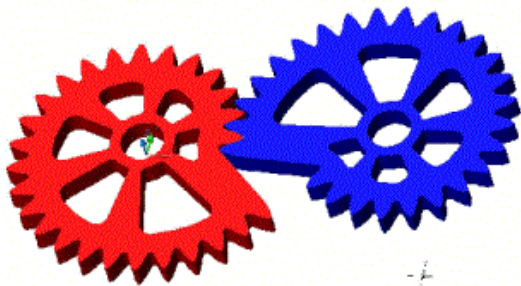

Fig. 1.6. **Noncircular gears with logarithmic centrodes** [21]

Special trajectories led to the driven element, noncircular gears are used either to replace or to drive classic bar mechanisms (Fig. 1.7) and literature provides numerous studies conducted by scientists ([29], [30], [31], [32], [33], [34], [35], [36], [37], [38], [39]).

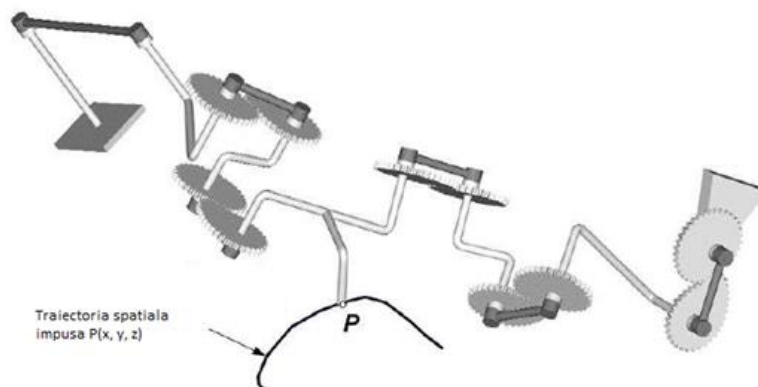

Fig. 1.7. **Special mechanism with noncircular gears** [32]

1.3. INDUSTRIAL APPLICATIONS FOR NONCIRCULAR GEARS

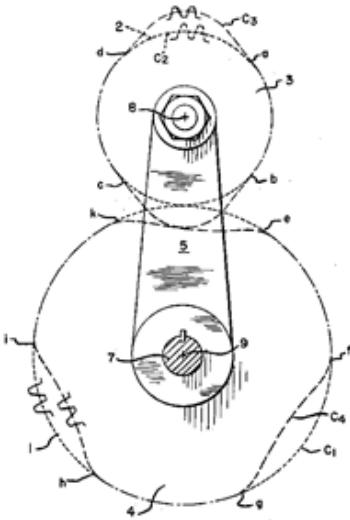

Fig. 1.8. **Freudenstein mechanism** [24]
1, 2 – noncircular gears; 3, 4 – noncircular gears; 7 – input axel
8 – output axel

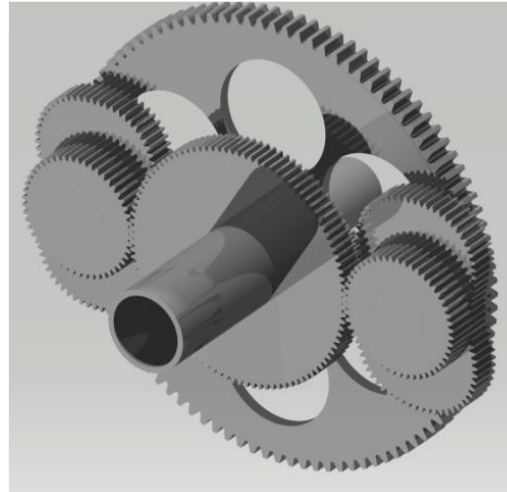

Fig. 1.9. **Mechanism proposed by Doric** [26]
to replace Geneva mechanism

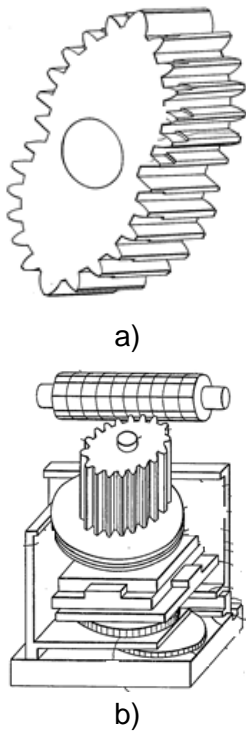

Fig. 1.10. **Elliptical gear for fluid pumping devices (a) and the generation teeth device (b) proposed by Kitano**

[40]

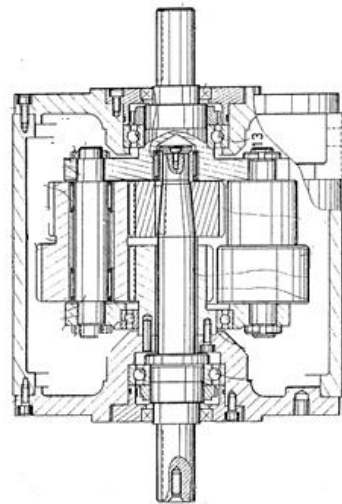

Fig. 1.11. **Planetary gear with noncircular gears** [41]

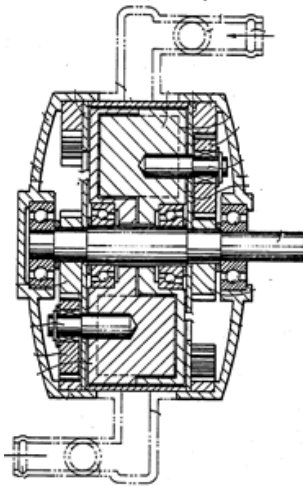

Fig. 1.12. Rotary pump with noncircular gears proposed by Takami [42]

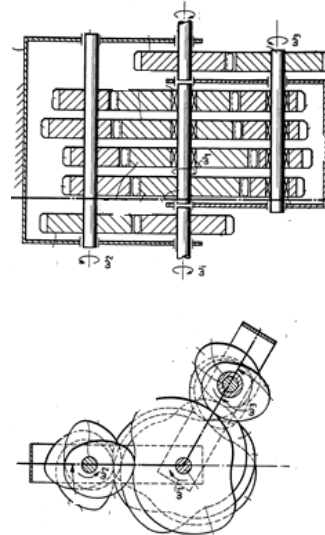

Fig. 1.13. Gearbox with three noncircular gears [43]

1.4. NONCIRCULAR GEARS DESIGN

The complexity of the geometric characteristics of the non-circular gears, corresponding with a variety of types of movements that can be performed by them, make noncircular gear design process unable to be standardized. However, the literature highlights two key steps in the design process:

(I) *Modeling of noncircular pitch curves.* The pitch curve is the the defining element of a noncircular gear along which teeth are disposed.

(II) *Teeth generation.*

The fundamental principle underlying the design of noncircular gears is the rolling principle specifying that the centrodes are in every moment of rotation tangent in the center of instantaneous rotation, rotate to each other without slipping and every spring from a centrode is printed with the same length on thr conjugated centrode.

1.4.1 Noncircular pitch curves design

Based on analysis of the field research, centrodes modeling procedures approached by scientists are grouped into three broad categories defined categories of original design data constituting the working hypothesis appropriate operating requirements

(i) *the instantaneous transmission ratio hypothesis;*

(ii) *the driving centrode hypothesis,*

(iii) *the output motion hypothesis*

1.4.2. Generation of noncircular gears teeth

Generating noncircular gears teeth is the main challenge in designing a noncircular gear due to the complex geometry that does not allow standardization process. If in the case of the gears circular generation teeth is based on deployment of the base, for noncircular gears

base curve does not allow the teeth modeling and thus can not be used as a reference in the design stage ([79], [80]).

1.4.3. Manufacturing of noncircular gears

The literature shows the processing of noncircular gears both by conventional methods, and the modern methods based on the CAD model of the wheel or by electro-erosion cutting, laser cutting and water jet cutting and abrasive. Classical methods are specific standard the teeth (running, copying) with appropriate technological equipment modified wheel alignment; but generate profiled using tools such as milling or finger-mode disk module, discrete division is not recommended because processing is low productivity [2]. Also, the use of template-wheel, etc. to more kinematic chains, adversely affect the processing accuracy and complexity of the equipment [101]. Kitano [40] patents the processing machine adapted to generate the elliptical toothed wheels of the toothed modeled with different pressure angles. R. Crow proposes a simplified solution for machine kinematics of gear non-circular contour or a work machine slotting circular cylindrical wheel with knife - wheel [102]. Vanin and Kolodin also propose a simplified kinematic wheel drive gear cutting circular milling [103].

CAP. 2. HYPOTHESIS FOR NONCIRCULAR CENTRODES DESIGN

2.1. INTRODUCTION

For the conjugate centrodes modelling process, three hypotheses were considered, as mentioned in literature, as follows:

Hypothesis 1, *the instantaneous transmission ratio hypothesis*, assumes that the instantaneous transmission ratio variation and the center distance are defined and the conjugate centrodes should be modelled, described by polar or Cartesian equations;

Hypothesis 2, *the driving centrode hypothesis*, assumes that the geometry of the driving centrode is defined and the center distance, the conjugate centrode geometry and the transmission ratio should be determined;

Hypothesis 3, *the output motion hypothesis*, assumes that the driven centrode motion and center distance are defined and gears centrodes geometries and the transmission ratio should be find out, respectively.

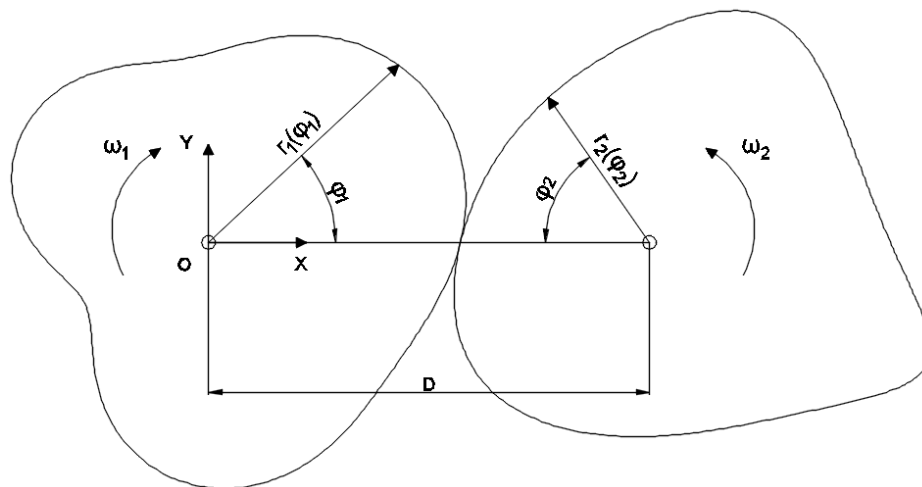

Fig. 2.1. Conjugated noncircular centrodes

2.2. HYPOTHESIS OF THE VARIATION LAW FOR THE TRANSMISSION RATIO

The assumption of the law of variation of the transmission ratio is, as initial data , the function describing the variation of the transmission ratio, $m_{21}(\varphi_1)$, the distance between axes D , the number of rotations of the two centroids, N_1, N_2 , over a period of rotation of the gear and the number of teeth that will have the driving centrode z_1 . The gear ratio must be a continuous, strictly positive, differentiable and regular. Based on these data , it determines the law of motion of driven centrode $\varphi_2(\varphi)$ and the geometries of the conjugated centrodes.

Fig . 2.2 . presents the calculation algorithm for generating centrodes assuming proposed transmission ratio.

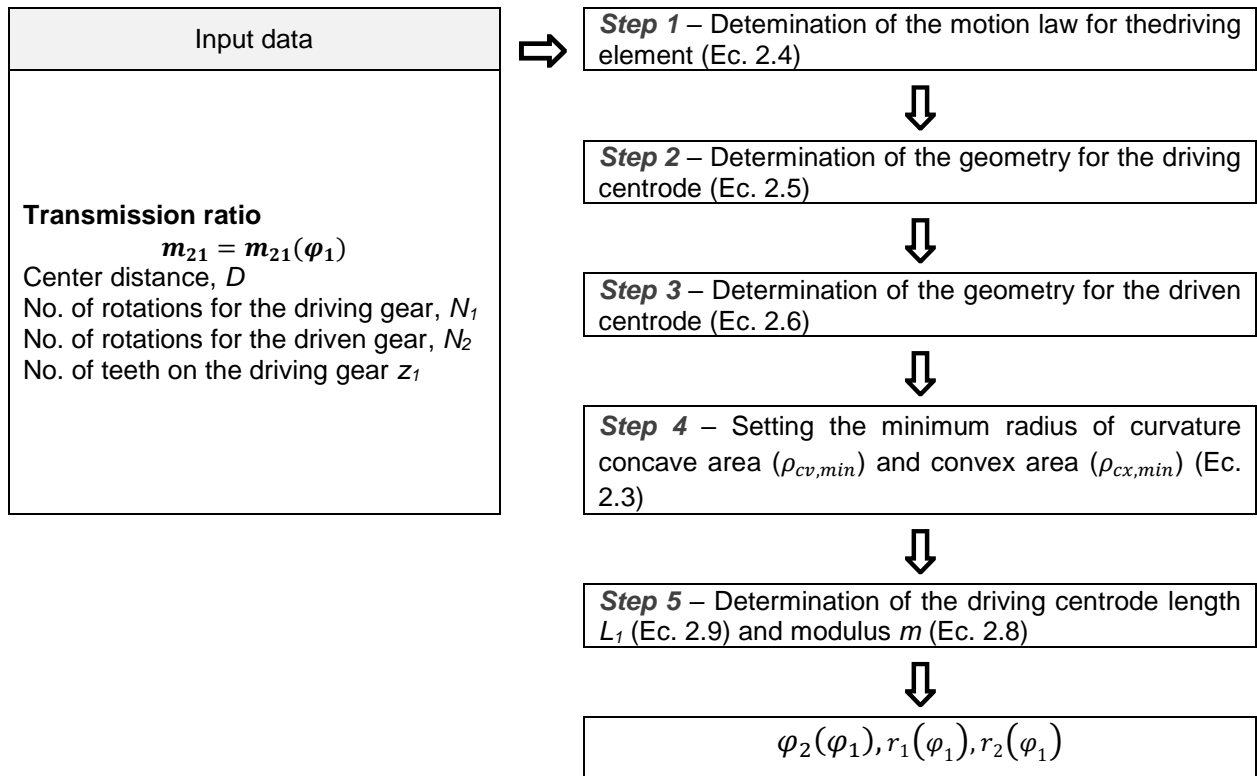

Fig. 2.2. **Algorithm for modeling conjugated noncircular centrodes in the transmission ratio law hypothesis**

The created application allows, using „AutoCAD data” option, to take data and import into the AutoCAD environment as a first step in processing teeth. However, plotting the conjugated centrodes in AutoCAD provides the necessary comparative study or even the possibility of an additional verification of the calculations by direct measurement, before moving to the next stage of design .

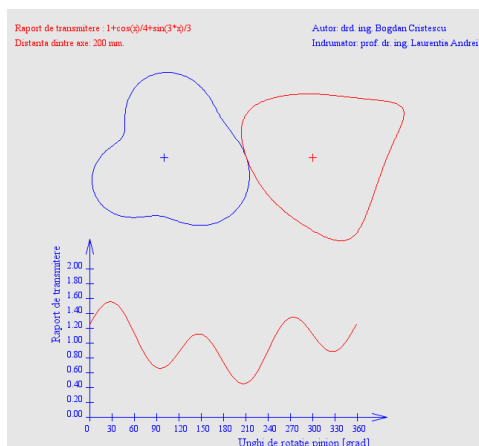

Fig. 2.3. **Graphical representation of the conjugated noncircular centrodes generated in PHP/HTML based on transmission ratio hypothesis**

Figura 2.5 illustrates AutoCAD representation of three pairs of conjugated centrodes generated based on algorithm in the assumption law describing the transmission gear ratio defined by :

$$m_{21}(\varphi_1) = 1 + \frac{\cos(\varphi_1)}{4} + \frac{\sin(3\varphi_1)}{5} \quad (2.12)$$

number of rotations $N_1 = N_2 = 1$, number of teeth $z_1 = 48$, with different values of the center distance.

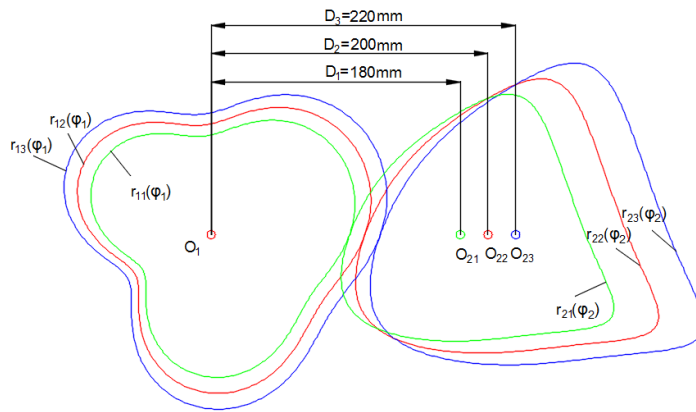

Fig. 2.5. Influence on the centrodes geometry of the center distance

Analysis of the distance between axes on noncircular centrodes geometry points out that higher values of the distance between axes determine an scaling effect on curves, curves with an increase in length and a reduction in the groove.

In Fig. 2.6 - 2.8 are shown examples of graphical representations of noncircular conjugated centrodes (Fig. 2.6a, 2.7a, 2.8a) generated in the case law of variation of transmission ratio described by different functions, according to the model in (2.13). It is also illustrated graphs of variation corresponding to the gear ratio, depending on the angle of rotation of the sprocket (Fig . 2.6b, 2.7b, 2.8b).

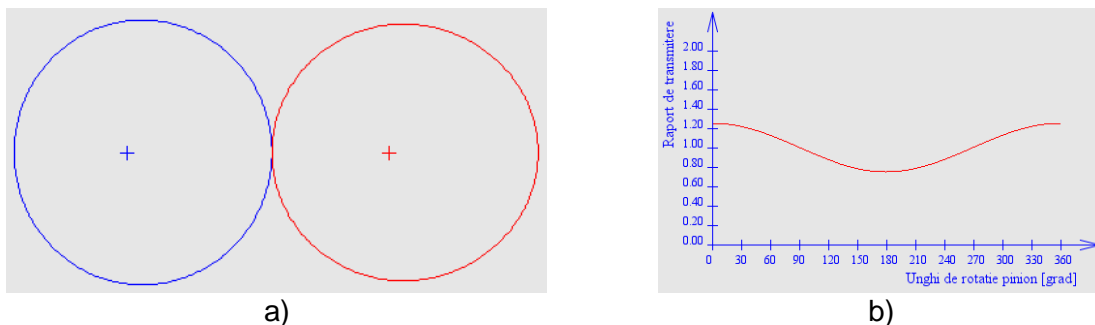

Fig. 2.6. Graphical representation of conjugated centrodes (a) and the law of variation of transmission ratio (b) with initial data: $m_{21} = 1 + \frac{\cos(\varphi_1)}{4}$; $D = 200$ mm; $N_1 = N_2 = 1$; $z_1 = 48$

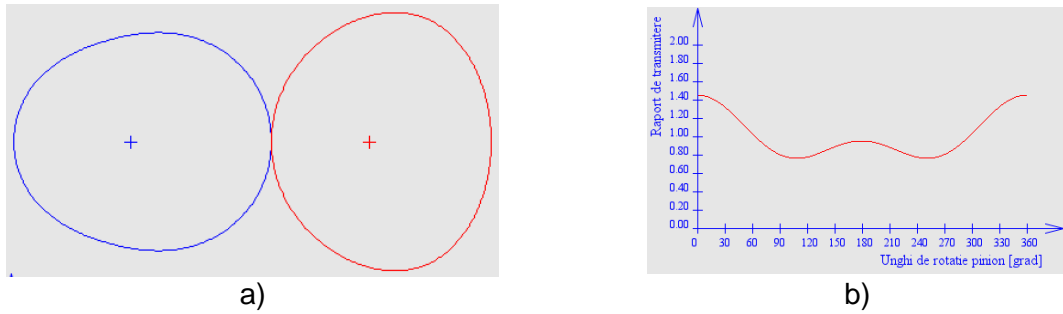

Fig. 2.7. Graphical representation of conjugated centres (a) and the law of variation of transmission ratio (b) with initial data: $m_{21} = 1 + \frac{\cos(\varphi_1)}{4} + \frac{\cos(2\varphi_1)}{5}$; $D = 200$ mm; $N_1 = N_2 = 1$; $z_1 = 48$

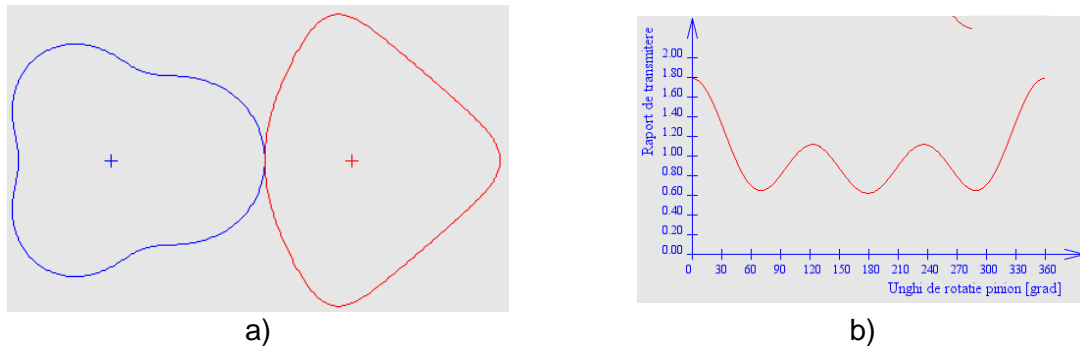

Fig. 2.8. Graphical representation of conjugated centres (a) and the law of variation of transmission ratio (b) with initial data: $m_{21} = 1 + \frac{\cos(\varphi_1)}{4} + \frac{\cos(2\varphi_1)}{5} + \frac{\cos(3\varphi_1)}{3}$; $D = 200$ mm; $N_1 = N_2 = 1$; $z_1 = 48$

2.3. HYPOTHESIS OF THE DRIVING CENTRODE GEOMETRY

Fig. 2.9 shows the algorithm based on which a PHP/HTML code was conceived for generating noncircular centres centroids, if the equation defining the geometry of driving centrod is known.

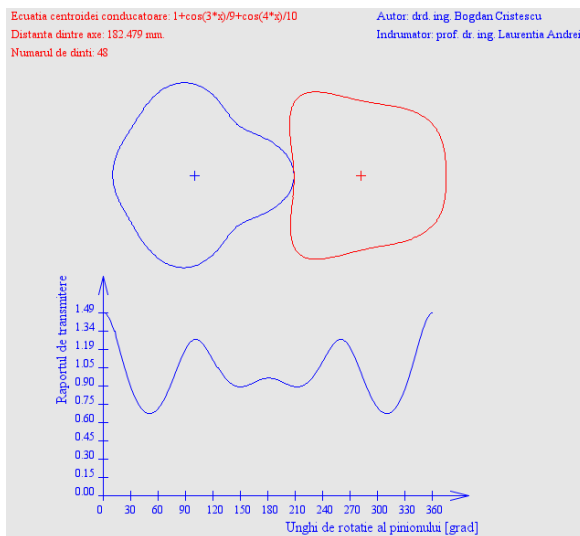

Fig. 2.10. Graphical representation of conjugated centres (a) and the law of variation of transmission ratio (b)

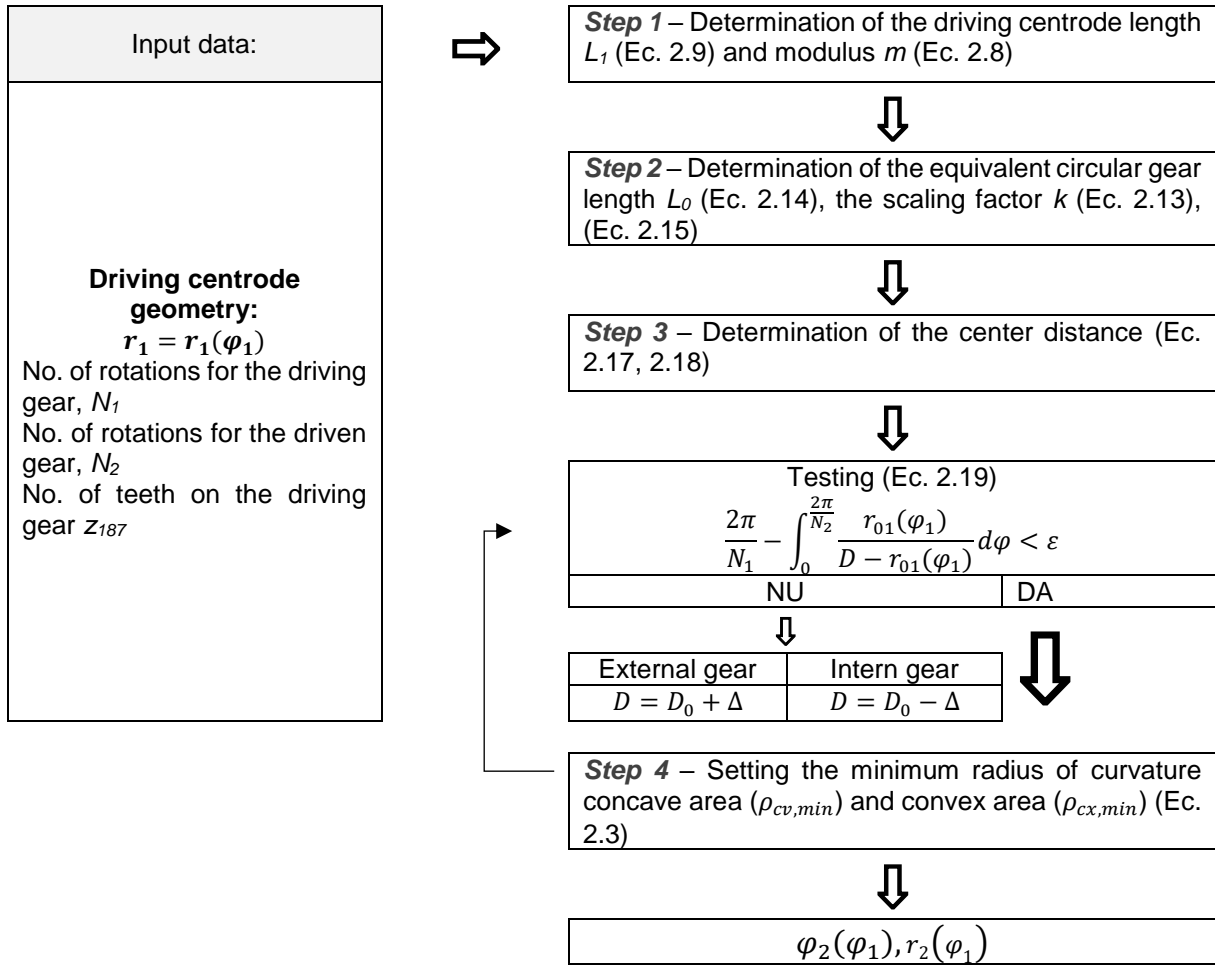

Fig. 2.9. Algorithm for modelling conjugated noncircular centrodes in the driving centrode geometry hypothesis

The created application provides graphic representations of conjugated centrodes, the variation of the transmission ratio and the value for the calculated center distance. Also, data can be imported into AutoCAD or subsequent shaping of the teeth or to assess the accuracy of the data by direct measurements and comparative studies. Figure 2.6 illustrates the representation of the PHP/HTML provided by the program designed for a noncircular gear which has the geometry of the centroid of the driving centrode expressed by equation (2.23), the number of revolutions performed by the pinion $N_1 = N_2 = 1$ and a number of teeth $z_{1c} v./ = 48$. the distance between axles is obtained $D = 182.479$ mm .

$$r_1(\varphi_1) = 1 + \frac{\cos(3\varphi_1)}{9} + \frac{\cos(4\varphi_1)}{10} \quad (2.23)$$

Figure 2.11 illustrates the comparative three pairs of conjugated centrodes generated in driving centrode geometry hypothesis expressed by Ec. (2.24), $N_1 = N_2 = 1$ and different values of the teeth number: $z_{11} = 36$, $z_{12} = 48$, $z_{13} = 54$.

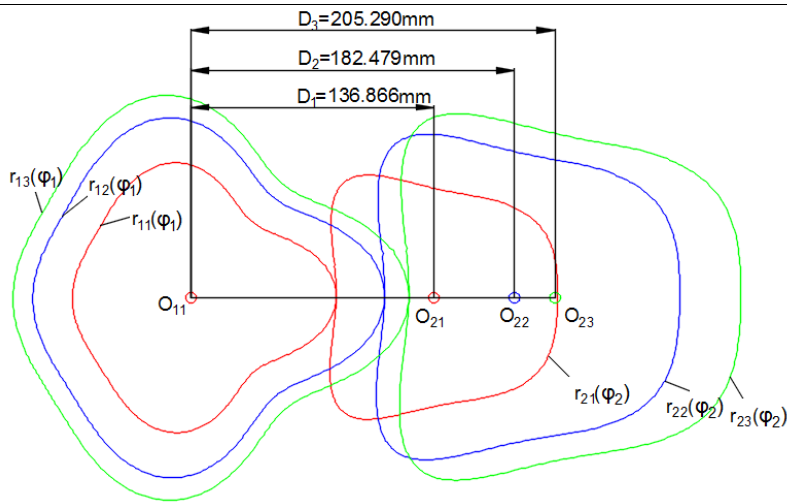

Fig. 2.11. Comparative graphical AutoCAD representation for conjugated centrodes generated in driving centrode geometry hypothesis

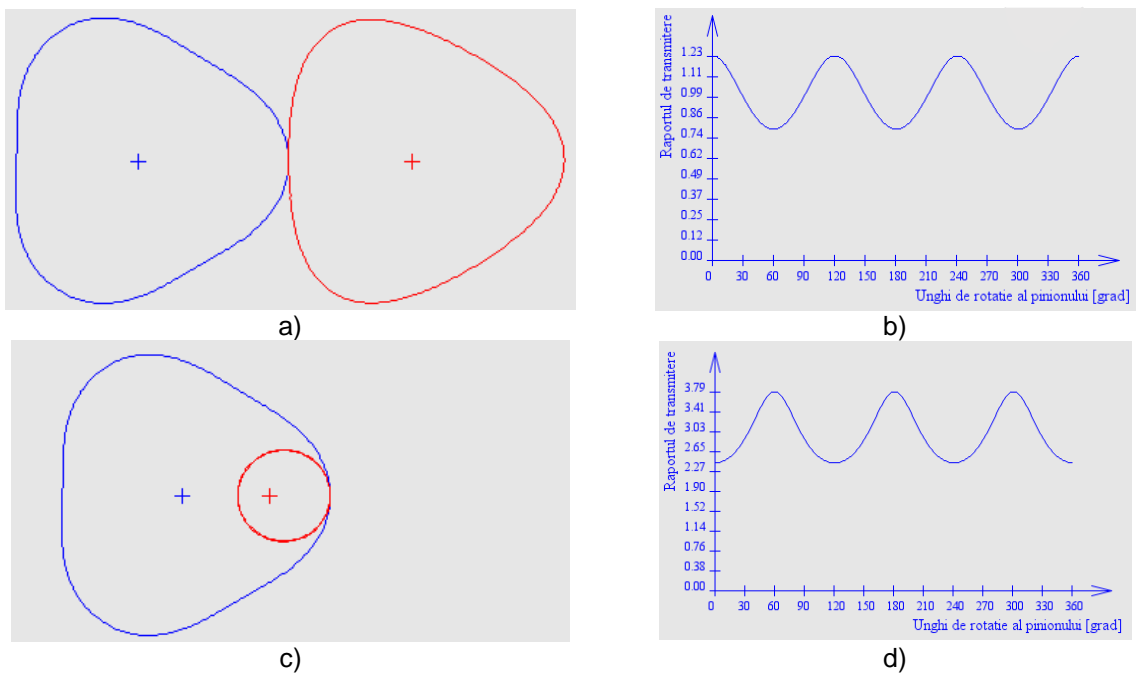
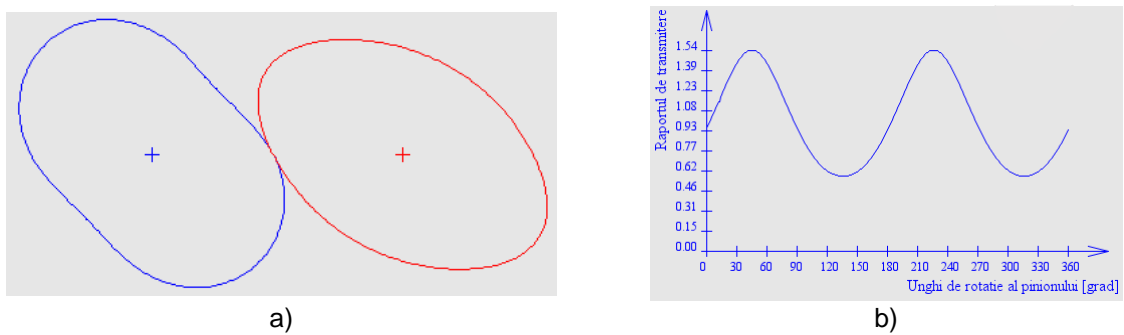

Fig. 2.12. Graphical representation of conjugated centrodes (a) and the law of variation of transmission ratio (b) with initial data: $r_1(\varphi_1) = 1 + \frac{\cos(3\varphi_1)}{9}$; $N_1 = N_2 = 1$; $z_1 = 48$



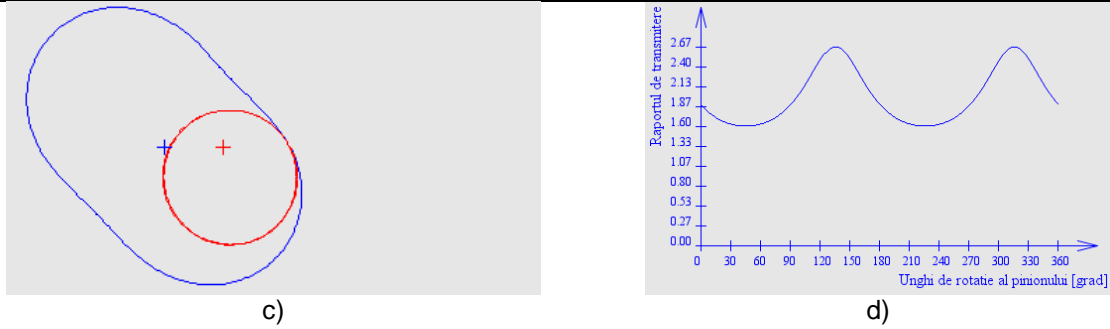

Fig. 2.13. Graphical representation of conjugated centrodes (a) and the law of variation of transmission ratio (b) with initial data: $r_1(\varphi_1) = 1 + \frac{\cos(2\varphi_1)}{4} + \frac{\sin(2\varphi_1)}{6}$; $N_1 = N_2 = 1$; $z_1 = 48$

2.4. HYPOTHESIS OF THE DRIVEN CENTRODE KINEMATICS

The algorithm that allows the generation of conjugated noncircular centrodes if the law of motion of the driven element hypothesis is shown in Fig. 2.14.

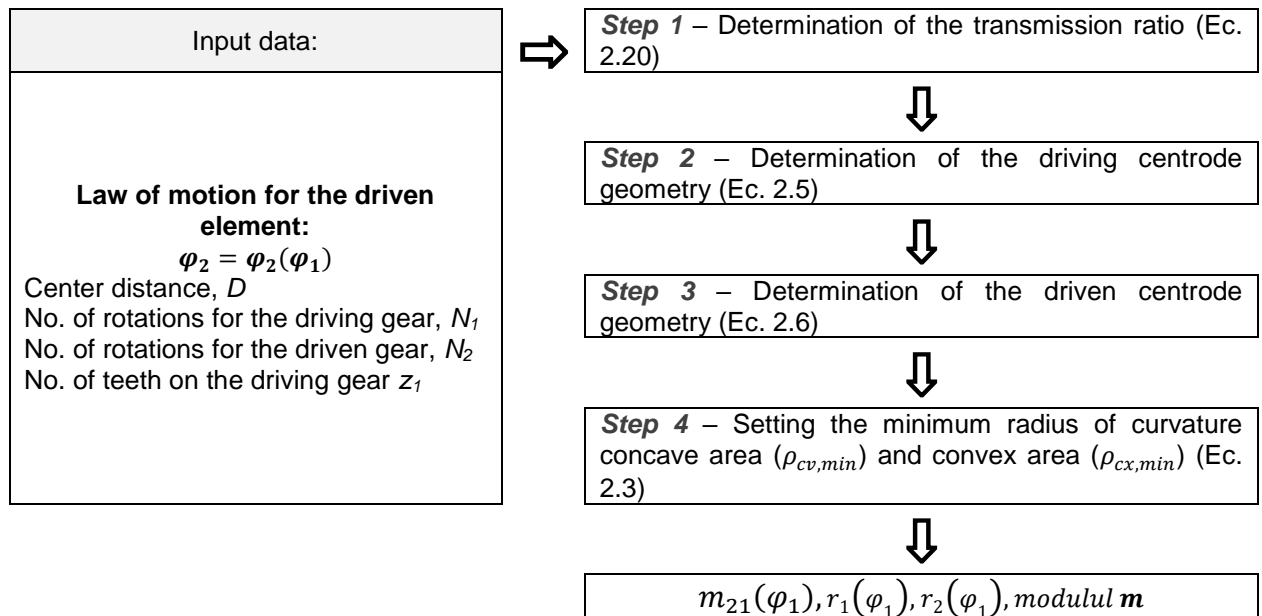

Fig. 2.14. Algorithm for modeling conjugated noncircular centrodes in the transmission ratio hypothesis

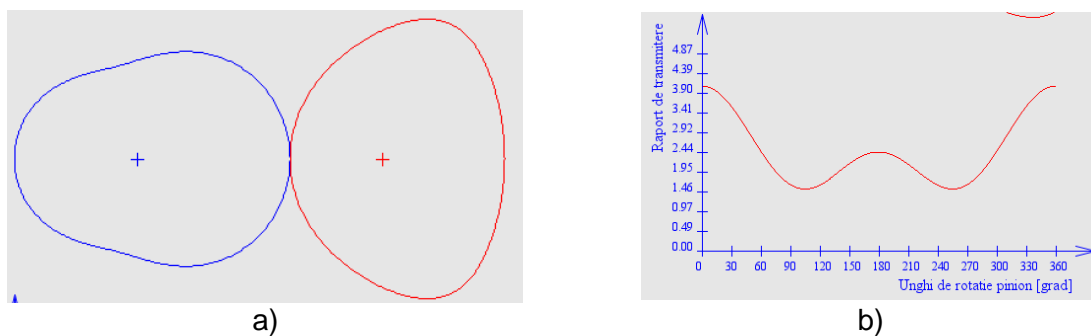

Fig. 2.15. Graphical representation of conjugated centrodes (a) and the law of variation of transmission ratio (b) with initial data: $\varphi_2(\varphi_1) = \varphi_1 + \frac{\sin(\varphi_1)}{3} + \frac{\sin(2\varphi_1)}{6}$; $D = 200$ mm; $N_1 = N_2 = 1$; $z_1 = 48$

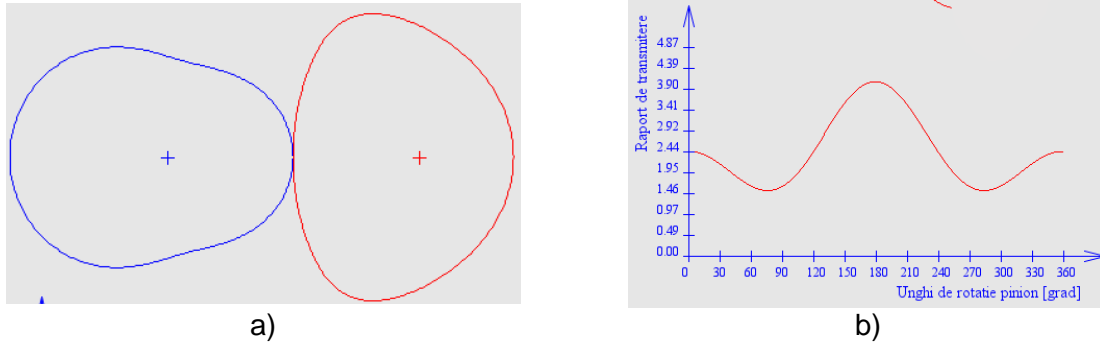

Fig. 2.16. Graphical representation of conjugated centrodes (a) and the law of variation of transmission ratio (b) with initial data: $\varphi_2(\varphi_1) = \varphi_1 - \frac{\sin(\varphi_1)}{3} + \frac{\sin(2\varphi_1)}{6}$; $D = 200$ mm; $N_1 = N_2 = 1$; $z_1 = 48$

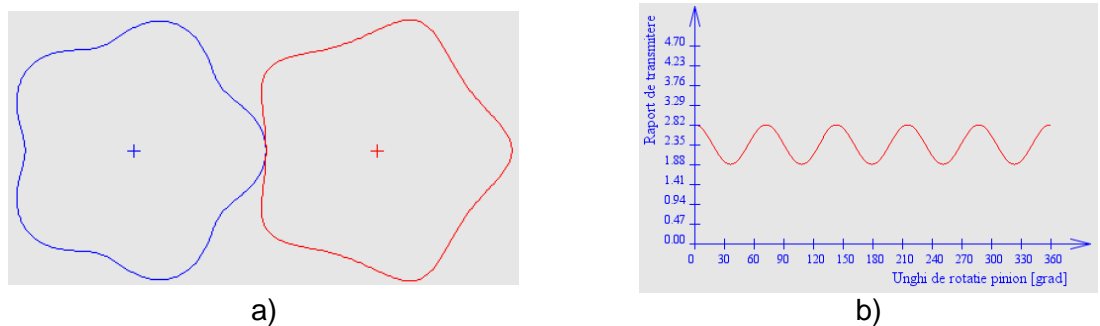

Fig. 2.17. Graphical representation of conjugated centrodes (a) and the law of variation of transmission ratio (b) with initial data: $\varphi_2(\varphi_1) = \varphi_1 + \frac{\sin(5\varphi_1)}{25}$; $D = 200$ mm; $N_1 = N_2 = 1$; $z_1 = 48$

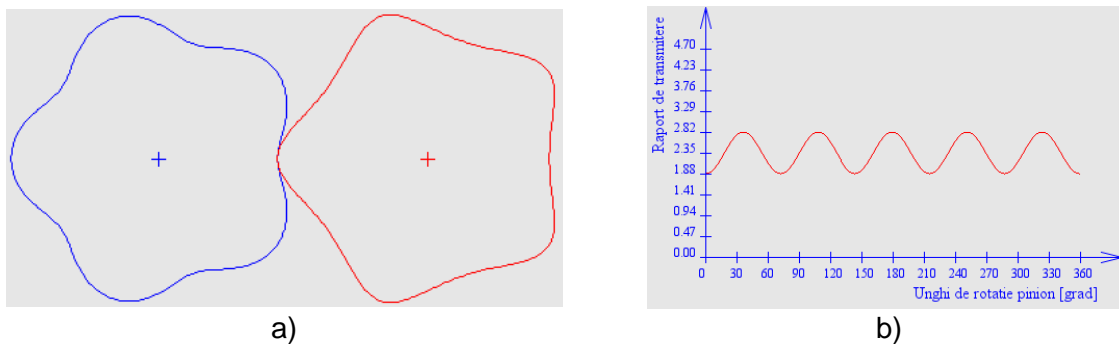

Fig. 2.18. Graphical representation of conjugated centrodes (a) and the law of variation of transmission ratio (b) with initial data: $\varphi_2(\varphi_1) = \varphi_1 - \frac{\sin(5\varphi_1)}{25}$; $D = 200$ mm; $N_1 = N_2 = 1$; $z_1 = 48$

CAP. 3. NONCIRCULAR GEARS TEETH GENERATION

3.1. INTRODUCTION

Generating teeth on noncircular gears involves (i) modeling of the generator curve, the tooth flank profile respectively, and (ii) the generation of the guiding curve or curve for the arrangement of the tooth on width of the gear. Depending on how the tooth flank is generated, two types of generators are different:

- I. materialized generator
- II. cinematic generator.

In order to emphasize the geometry of curves based on the noncircular toothed wheels, based on a predefined pitch curves, the following assumptions inspired by the theory of standard gears (Fig. 1.1):

- CB1 hypothesis. Base curve is the locus of points where the perpendicular T to the center of rotation of the wheel intersects the line of engagement;
- CB2 hypothesis. Base curve is the locus of points situated T versus current points on the pitch circle at a distance equal to the radius of curvature of involute PT, which would pass through that point as calculated in Fig. 1.1.

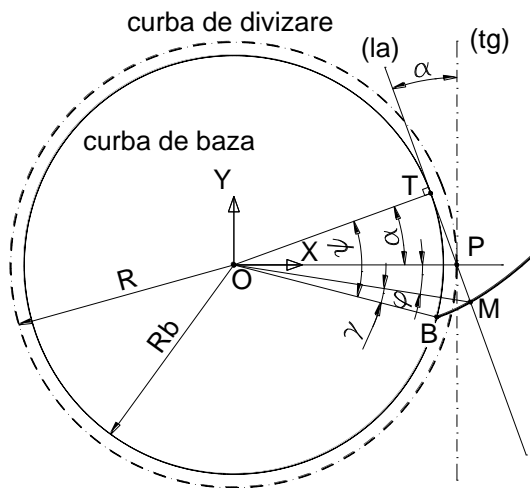

Fig. 3.1. Evolvent circle

P = instantaneous center of rotation
(pole engagement)

(Tg) = right on the pitch circle tangent

(At) = right running on the base circle
(normal to the involute)

M = current point on the involute $M \in$
(tg)

B = the point of involute curve which is
generated

T = the perpendicular leg (la), located
on the base circle

φ = angle radius vector of the current
format of the current point involute E

$$\psi = \alpha + \varphi + \gamma \Rightarrow$$

$$\gamma = \tan(\alpha + \varphi) - (\alpha + \varphi) = \text{inv}(\alpha + \varphi)$$

3.3. KINAMATIC GENERATION OF THE TEETH FLANKS PROFILES

Hypothesis 1 (IpGC1) considers generating accurate kinematic profile tooth flank [116], [2]. During the rolling, the rackcutter pitch line is tangent to the pitch curve, permanently changing its orientation. Thus generating tooth flank and intersecting curve of the gear spin E_i point (Fig. 3.6a), the rackcutter is positioned with the pitch line (l.d.c.) and tangent to the pitch curve, forming angle μ_i with the current radius $r(\varphi_i)$, and receives the movement running in the vicinity of them in both directions, for generating the head and foot areas of the tooth, respectively. In a current point in the vicinity of E_i , rack pitch line has orientation (l.d.c) ij , forming angle μ_{ij} , variable radius vector r_{ij} , the current point of contact. For some concave-convex pitch curves, the tooth profile generated will be referred to in subsequent studies, GCP profile (generated cinematic precise).

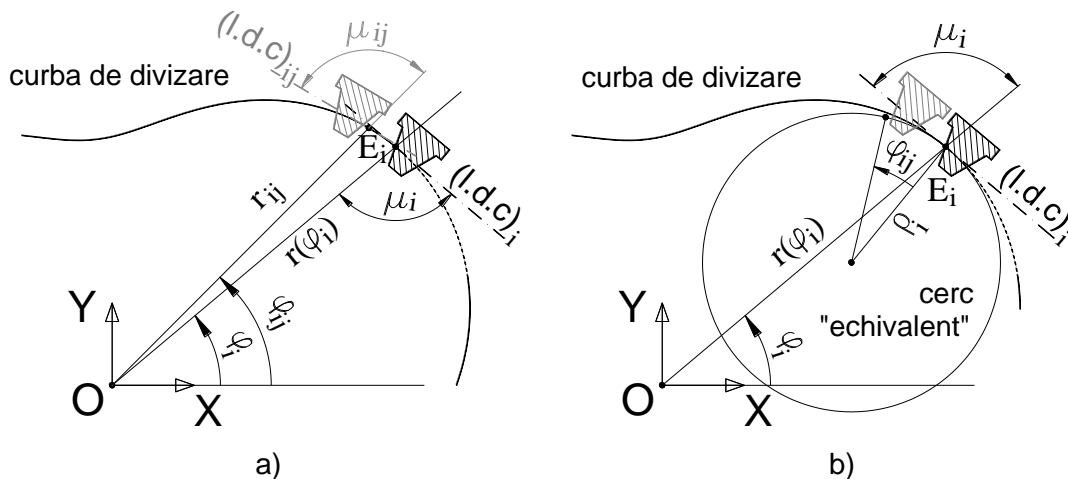

Fig. 3.6. Hypothesis generating accurate kinematic (a) and "approximate" (b) tooth flank profile

Hypothesis 2 (IpGC2) considers the generation of cinematic "approximate" tooth flank profile assimilating non-circular pitch curve in the vicinity of E_i , the arc of a circle 'equivalent', with ρ_i equal to the radius curvature (Fig. 3.6b). During rolling in the vicinity of E_i , rackcutter pitch line (l.d.c) as a tangent to the equivalent circle, retain their orientation on each tooth flank, but a change from one flank to another thus generating the active flank of the tooth.. Involute tooth flank profile will be, appropriately considered equivalent circle, and will be referred profile GCA (cinematic generated approximately).

To generate teeth, in both cases, it will be assumed that the teeth are willing on the pitch curve so as to ensure a constant angular pitch, which will induce a variable spacing along the pitch curve.

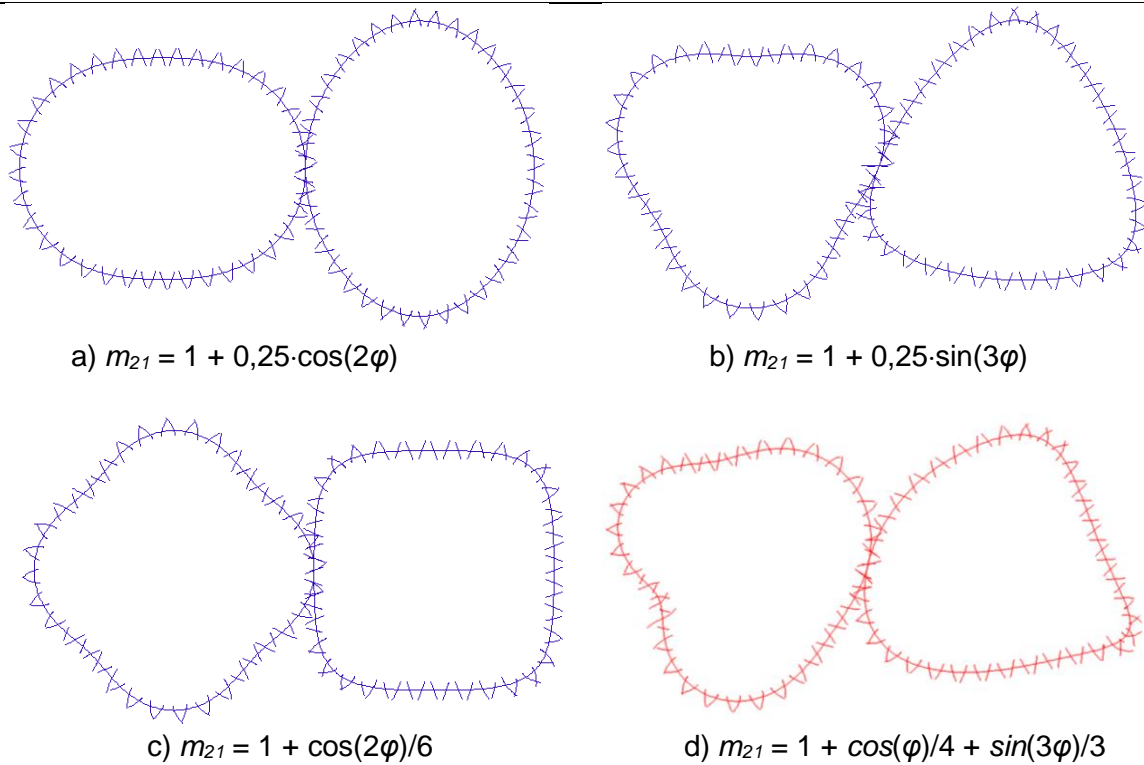

Fig. 3.13. GCP profiles of the noncircular gears teeth

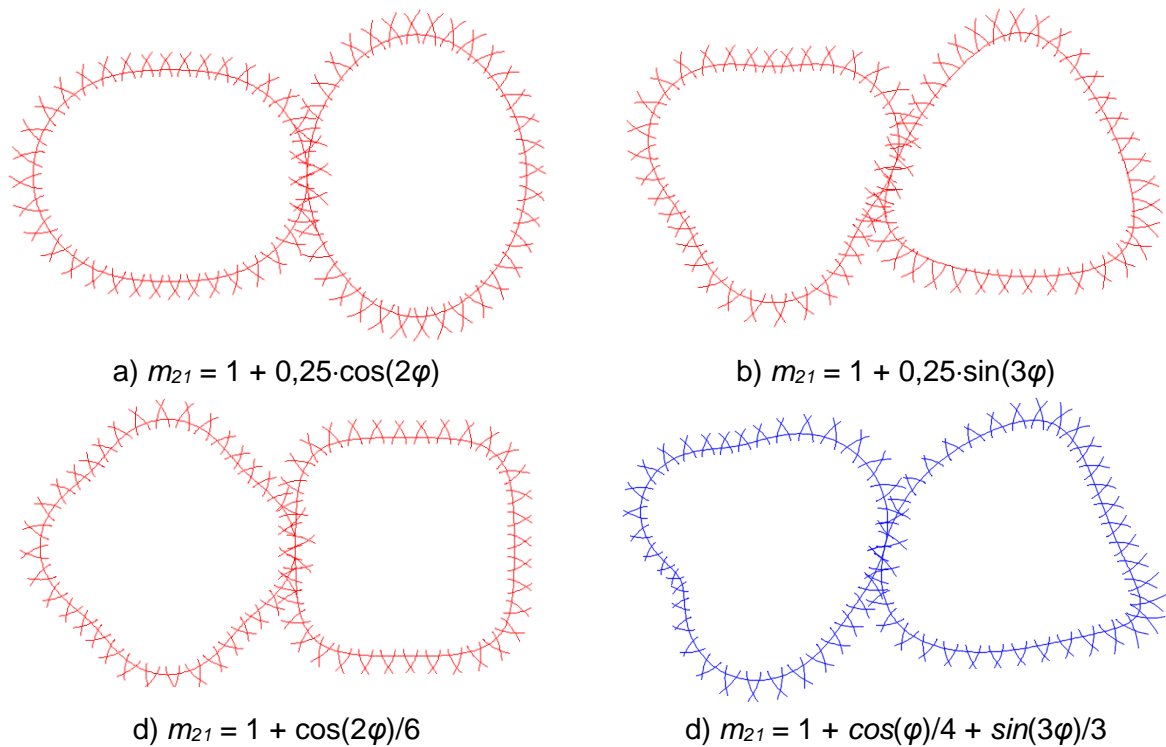

Fig. 3.16. GCA profiles of the noncircular gears teeth

Based on the presented algorithm was created a new original code PHP (Appendix 7), with which were generated pitch curves and CGA profiles teeth for noncircular gears generated for transmission ratio m_{21} , distance between axes D , angle of pressure $\alpha = 20^\circ$ and the rack teeth $z_1 = z_2 = 36$ (Fig . 3.16) .

3.3.3. Comparison between teeth flanks profiles

For comparative study of the geometrical characteristics of the teeth flanks cinematic generated by the two hypothesis, was generated teeth of a noncircular gear designed assuming instantaneous transmission ratio defined by (3.39). It is considered the distance between axes $D = 200$ mm and the number of teeth $z = 36$. The databases obtained using PHP code imported into AutoCAD and plotting is illustrated in Fig . 3.17.

$$m_{21} = 1 + \cos(\varphi)/4 + \sin(3\varphi)/3 \quad (3.39)$$

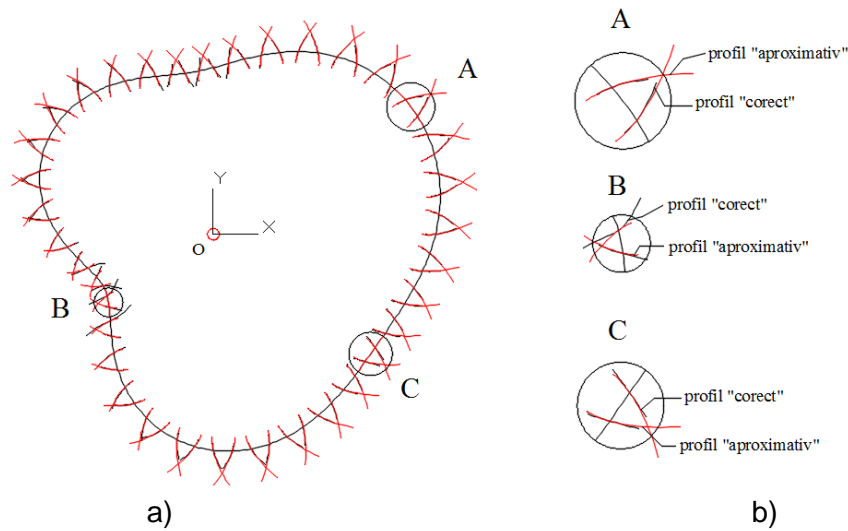

Fig. 3.17 CGP and CGA teeth profiles generated
a) complete dentures ; b) details of the teeth with small curvature (convex area - A), with the maximum curvature (concave area - B) and the almost linear - C

The comparison between CGA and CGP tooth profile flanks performed by analyzing patterns edited in AutoCAD, based on data provided by the PHP code, highlights differences in tooth profiles curves, which can be assimilated to travel profile.

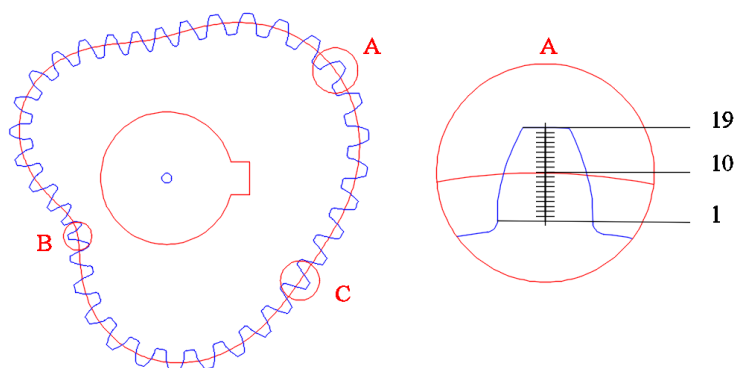

Fig. 3.18. Teeth selections for comparison analysis

The results of the comparative analysis carried out highlights a number of features of the tooth flank profile generated by the "correct" hypothesis:

- The tooth located in the convex are, the standard deviation in the foot ($7.95 \cdot 10^{-3}$ mm) is smaller than the area of the head ($10.39 \cdot 10^{-3}$ mm) which is explained by a smaller thickness of the tooth in the area of the foot, similar to "approximate" profile.
- For the concave area tooth (tooth B) deviation in the leg area is $10.63 \cdot 10^{-3}$ mm, and in the head area $12.58 \cdot 10^{-3}$ mm. Increased deviation in the head area is justified by the reduced thickness of the teeth generated correctly in accordance with the shape of the pitch curve in the minimum radius of curvature .
- In the rectilinear area tooth C shows a median of $10.41 \text{ mm} \cdot 10^{-3}$ in the foot and $9.36 \cdot 10^{-3}$ mm in the head .

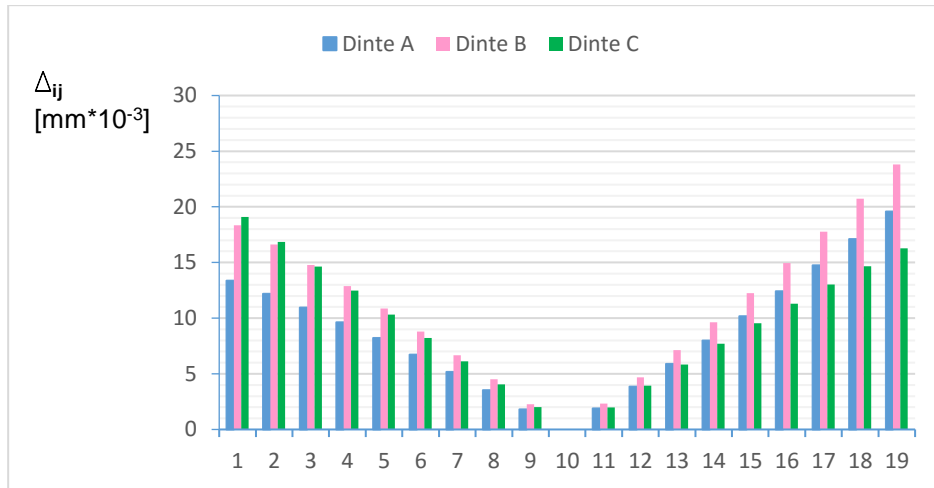

Fig. 3.19. Displacement variation between GCA and GCP profiles

3.3.4. Solid modeling of noncircular gears

Modeling solid noncircular gears is necessary both for their processing and for the final stage of the design process, respectively for analyzing the performance of engagement.

Figure 1.20 illustrates the solid models of the noncircular gears defined by the transmission ratio expressed by (3.39), assuming generation cinematic precise (Fig . 3.20) and approximate (Fig . 3.20b) profiles teeth flanks.

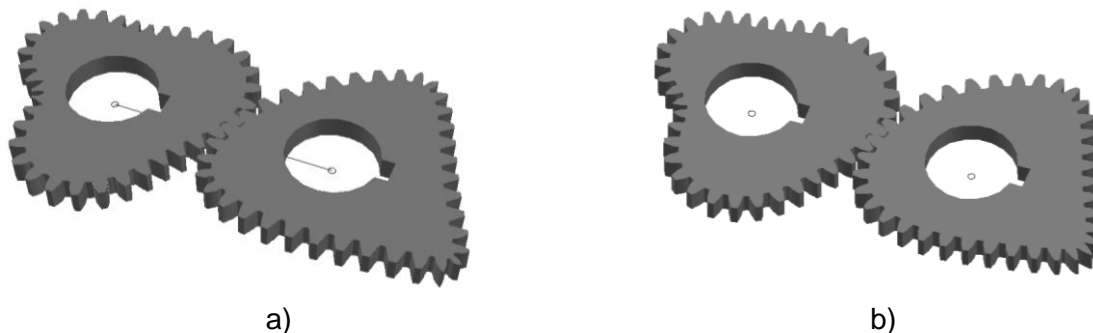

Fig. 3.20. Solid models of the noncircular gears generated in IpGC1 (a) și IpGC2 (b)

CAP. 4. NONCIRCULAR GEARS PERFORMANCES ANALYSIS

4.2. STATIC ANALYSIS OF NONCIRCULAR GEARS ENGAGEMENT PERFORMANCES

The study of the engaging conditions for noncircular gears in static mode is performed on solid models and is based on the accuracy of data provided by the program created in PHP to generate teeth. Static analysis of the conditions of engagement for noncircular gears is developed in two directions:

- Analysis of the contact between teeth through controlled interference, provides information on the contact surface ;
- The state of stress and strain analysis, based on existing principles in the study of cylindrical gears .

(a) Generation hypothesis influence

To study the influence of hypothesis generation on static contact between teeth were generated two noncircular gears designed assuming instantaneous transmission ratio defined by (4.1), both situations outlined above :

- AnGP1 - GC1 generated hypothesis, known as the generation of "precise" profile
- AnGA1 - GC2 generated hypothesis , called the generation of "approximate" profile

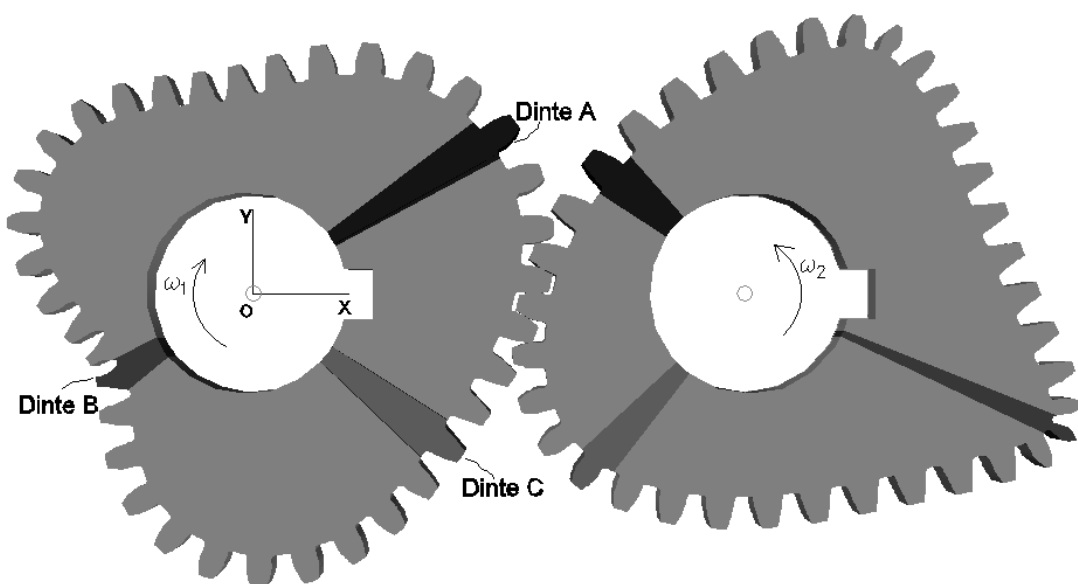

Fig. 4.1. The positioning of the analyzed teeth on the noncircular gears

4.2.2. State of stress and stain

Static analysis of the state of stress and strain is developed as follows :

1. Import in Inventor the solid model edited in AutoCAD (Fig . 4.8)

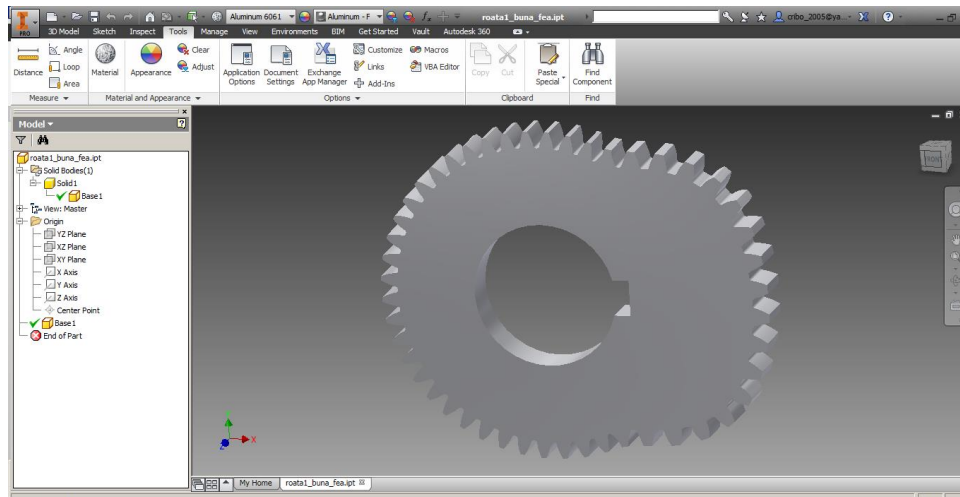

Fig. 4.8. Non circular gear represented in Autodesk Inventor

2. The choice of material from which is made the gear (Aluminiu 6061-T6);
3. Setting degrees of freedom/constraint: a degree of freedom, rotation around the axis Oz, constraining the gear hub;
4. The positioning force $F = 10 \text{ N}$ on the studied tooth crown, normal to the tooth surface in the direction of the line head, acting on the whole width of the tooth (Fig. 4.9);

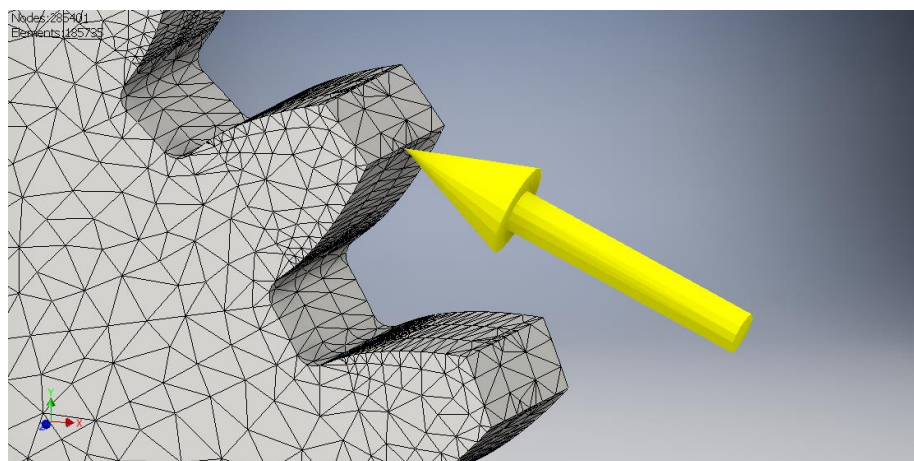

Fig. 4.9. Positioning of the force during engagement

5. Establishing the structure of finite elements (Fig . 4.10):
 - Average size of finite element (as a fraction of the space framing) : 0.1 ;
 - The minimum size of the finite elements (as a fraction of average size): 0.2 ;
 - The maximum angle of rotation of the 60°;
 - No. of nodes: 257 503, no. items: 167 286.

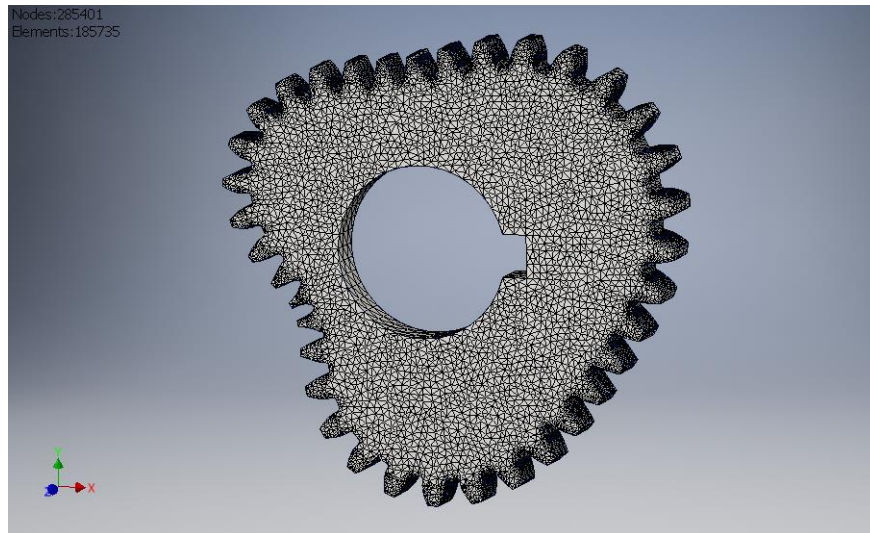

Fig. 4.10. **Decomposition of solid finite element model**

6. Simulation and execution of Von Mises stress distribution (Fig . 4.11), field strains (Fig . 4.12) and equivalent stress distribution (Fig. 4.13).

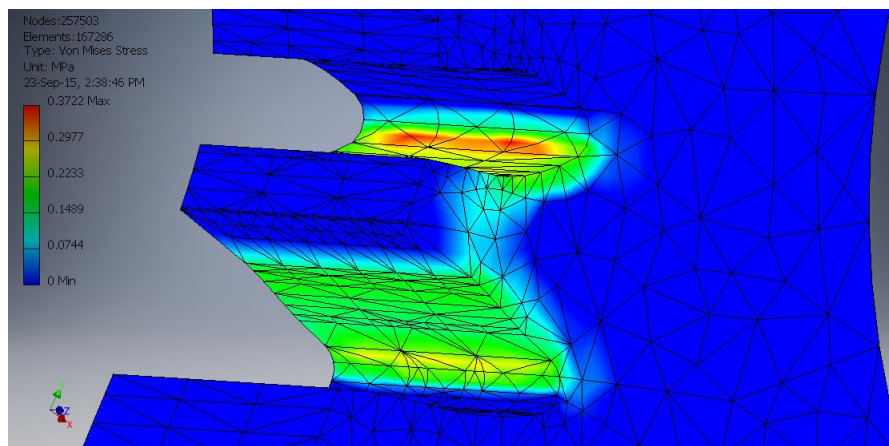

Fig. 4.11. **Von Mises stress distribution for non-circular gear tooth B AnGP2**

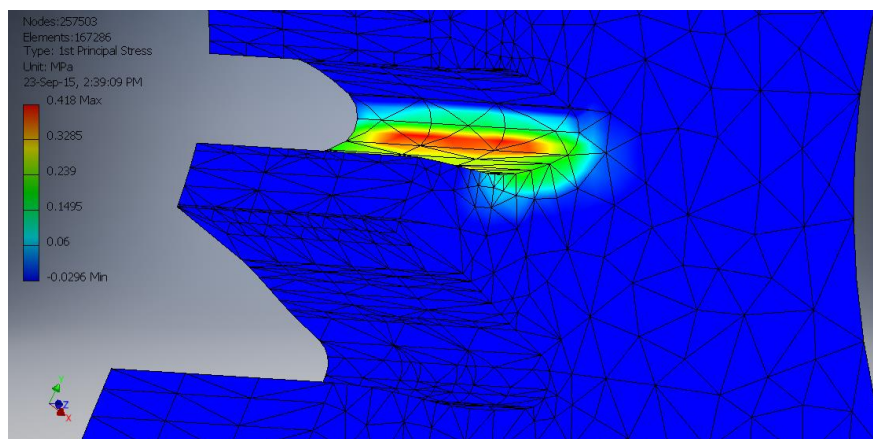

Fig. 4.12. **Equivalent stress distribution for non-circular gear tooth B AnGP2**

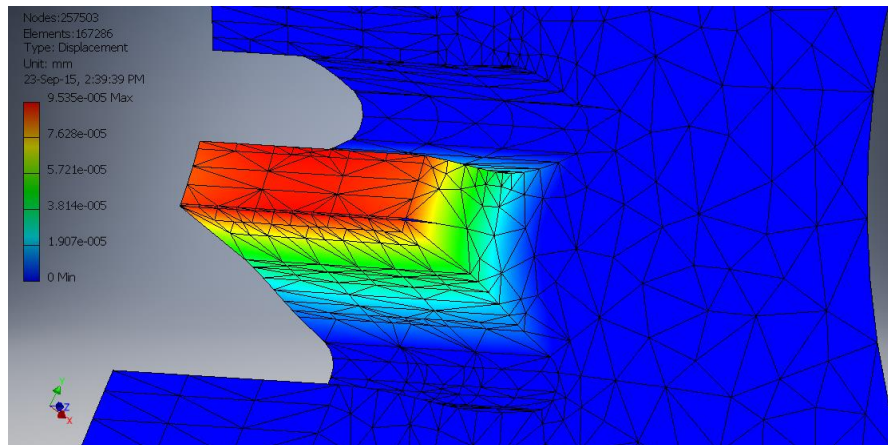

Fig. 4.13. Deformations field for non-circular gear tooth B AnGP2

4.3. DYNAMIC ANALYSIS OF NONCIRCULAR GEARS ENGAGEMENT PERFORMANCES

4.3.1. Dynamic simulation

Dynamic simulation is used during the design process of a prototype to study the interaction between parts of a whole and possible failures of components. Unlike static analysis gears engaging performance that is performed on an assembly component (in the case discussed above, the drive gear), dynamic simulation allows analysis by finite element assembly in conditions similar to those during the operation. Also, as opposed to static analysis by the FEM method provides results that depend on the correctness of the hypothesis established for the model calculation (uptake beam recessed tooth, the position and the size of the force, setting constraints, etc.), the study of stress and strain state based on dynamic simulation eliminates errors that may appear, this process is based on the second law of motion Newton's [138]. Thus, dynamic simulation created in INVENTOR take account of joints defined by the designer to determine the interactions between components, and constraints kinematic such as gravity, inertia forces, the forces of interaction between components, frictional forces, movements imposed , torques, etc.

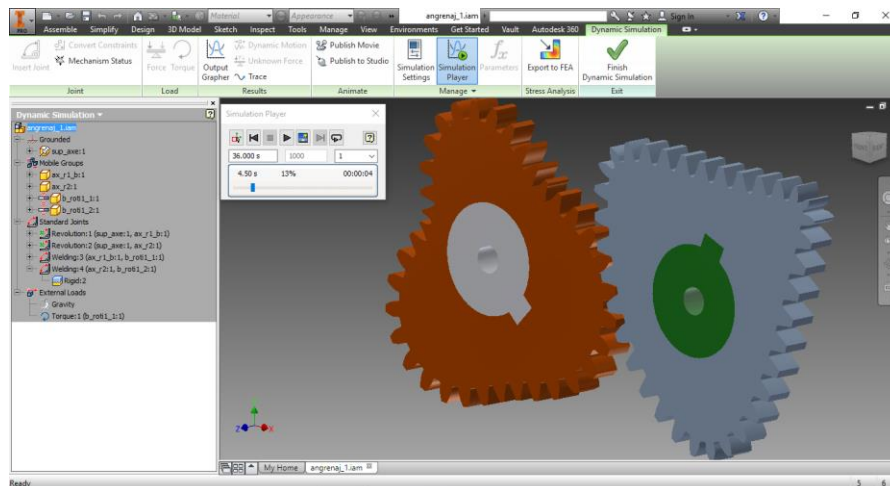

Fig. 4.27. Dynamic simulation in INVENTOR

4.3.2. Generation hypothesis influence on engagement performances

The analysis is performed on the two gears presented in section 4.1: AnGP1 generated by precise method and AnGA1 generated by approximate method. The algorithm presented above is the final step for the study of dynamic data export, export generating models for finite element based on elements summarized in Table 4.6. The results obtained characteristic state of stress and strain are shown in Table 4.7 .

Tabel 4.6. Characteristic elements for the study of dynamic method of FEM – noncircular gears and AnGA1 AnGP1

	AnGP1	AnGA1
Nodes	258995	267775
Elements	168387	173513

The engagement performances through dynamic simulation provides global information, highlighting areas where driving wheel appear extreme values of stresses and strains , and their maximum amounts.

Tabel 4.7. Data on the state of tension and strain obtained by dynamic simulation for gears AnGP1 și AnGA1

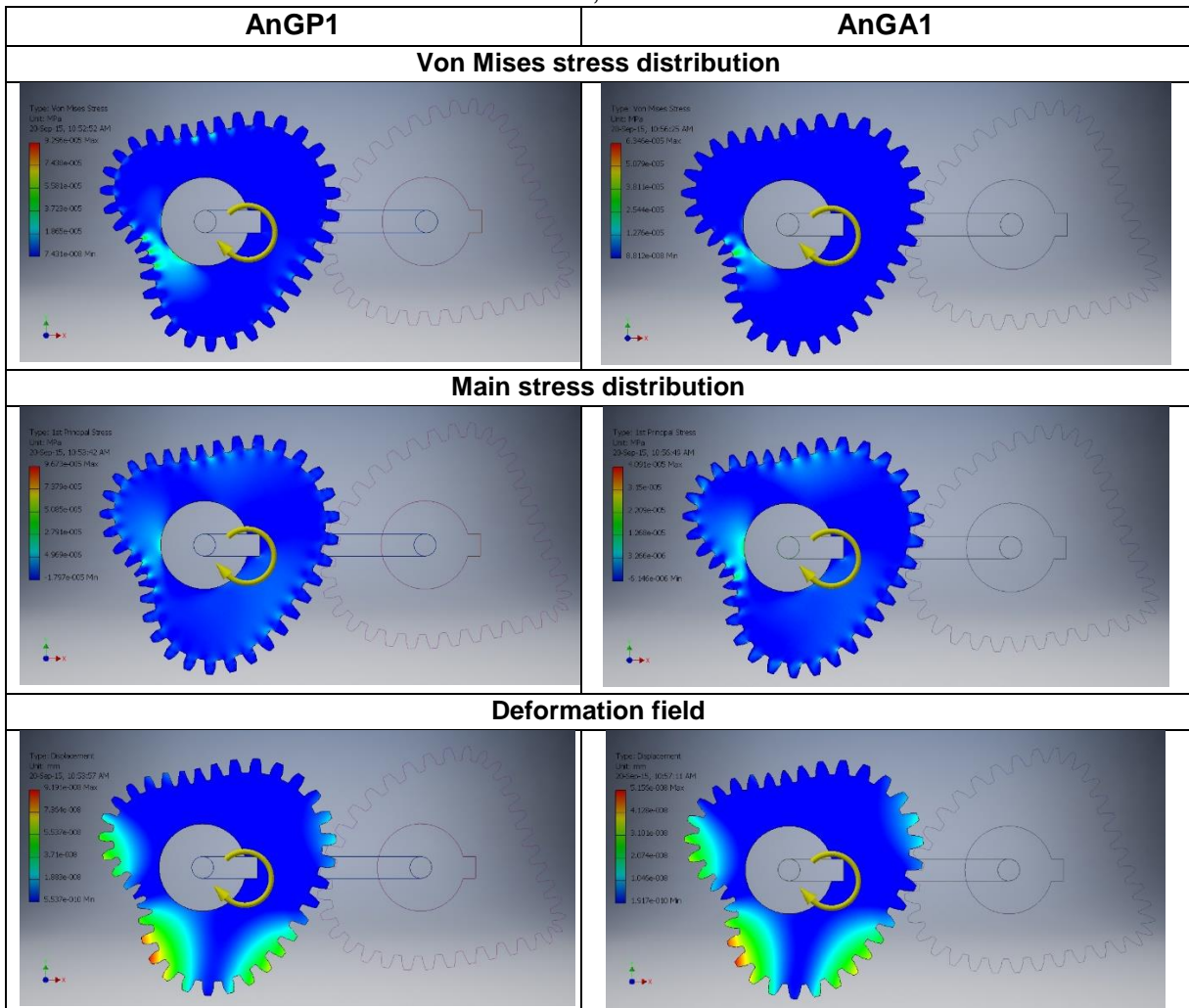

Analyzing the images presented in Table 4.7 shows that the main stresses and tensions Von Mises in concave area show high values of pinion gears for both. The deformation field has a distribution similar for both AnGP1 and for AnGA1, with higher values in convex areas with large radius of the centrode, particularly those located in the vicinity of the concave areas.

Graphic representations shown in Figure 4.31, b and c are drawn based on data obtained from dynamic simulation analysis of the stress and stans state and give a comparison between the values obtained for each gear.

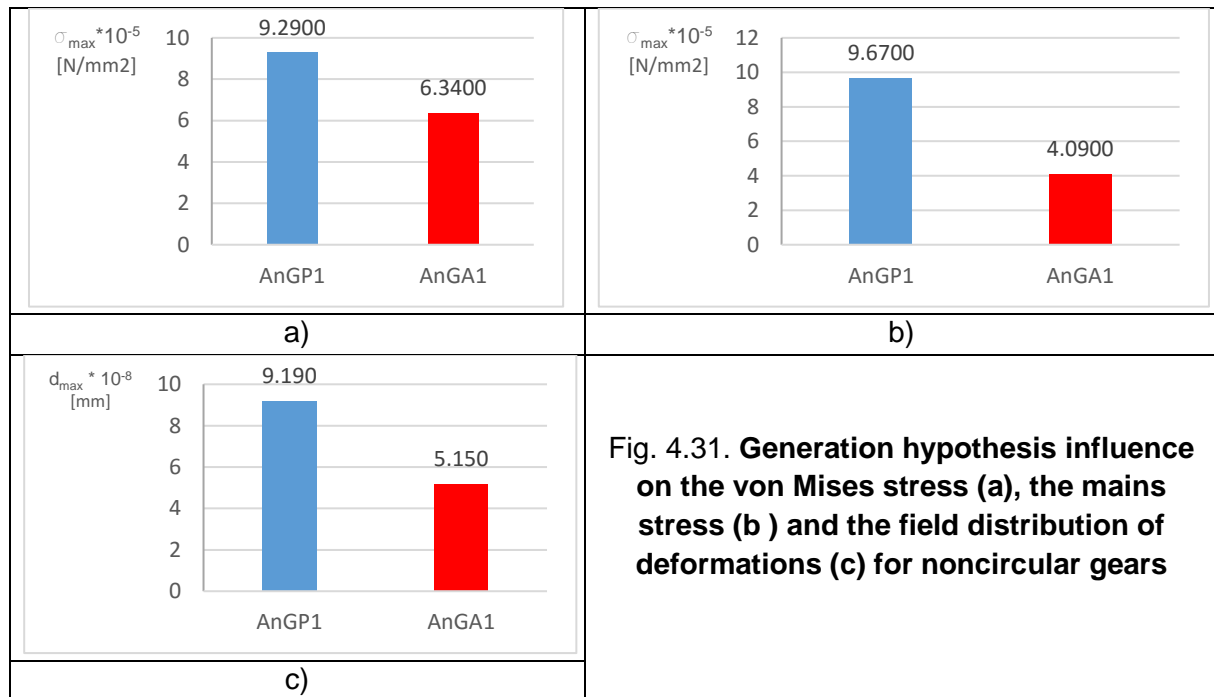

Fig. 4.31. Generation hypothesis influence on the von Mises stress (a), the mains stress (b) and the field distribution of deformations (c) for noncircular gears

The noncircular gear generated by the approximate method present higher performances achieved through dynamic simulation than those for gears generated by precise method. Thus, the maximum Von Mises stress is 31.75 % lower in gear AnGA1, main stress with 57.70 % and the maximum displacement decreases by 44.45 %. The results confirm the analysis in static mode as highlighted also engaging performances higher quality in the concave gear generated by the approximate method.

4.3.3. Pressure angle influence on engagement performances

To study the influence of design parameters on the conditions for engaging by dynamic simulation method, are analyzed three different gear pressure angle (AnGP1 , AnGP2 and AnGP3) and go through the steps of the algorithm described above. The characteristic features of patterns generated by the method FEM analysis are shown in Table 4.8 and the results regarding the state of stress and strain obtained by the dynamic simulation, in Table 4.9 .

Tabel 4.8. Characteristic elements for the study of dynamic method of FEM – noncircular gears AnGP1, AnGP2 and AnGP3

	AnGP1	AnGP2	AnGP3
Nodes	258995	267775	276306
Elements	168387	173513	179864

Tabel 4.9. . Data on the state of tension and strain obtained by dynamic simulation for gears AnGP1, AnGP2 and AnGP3

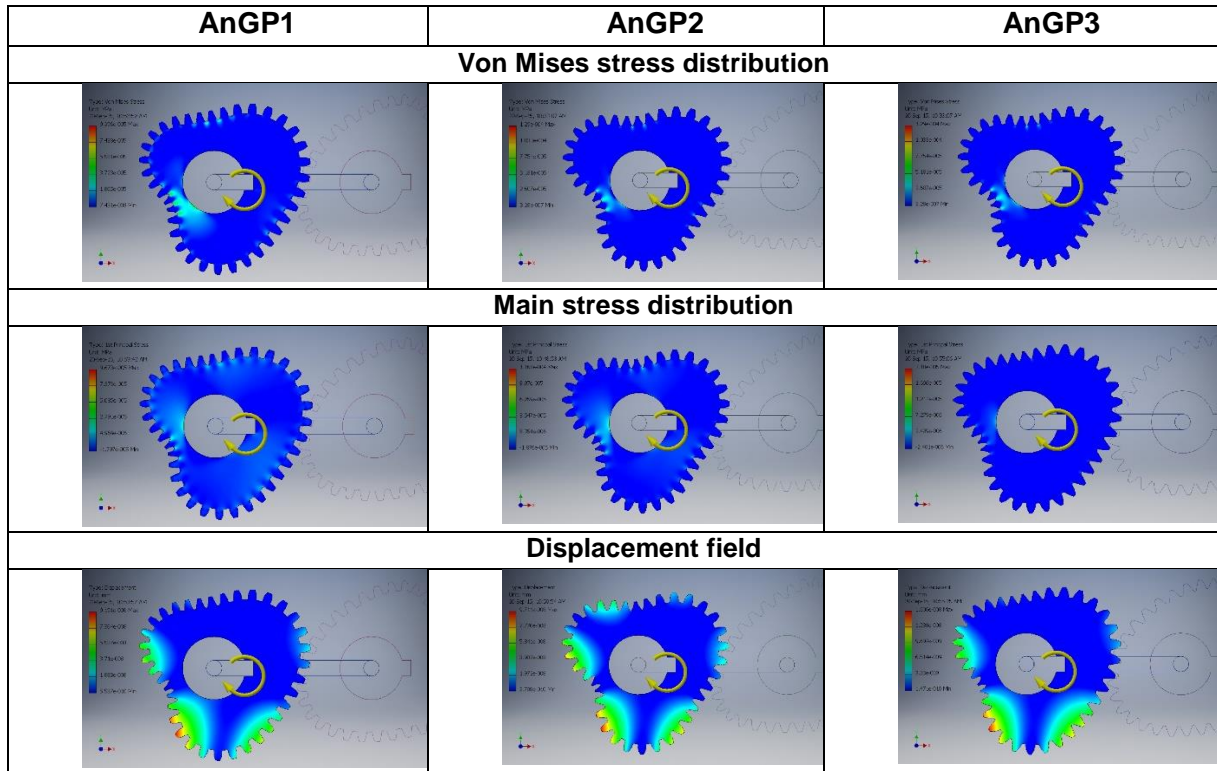

CAP.5. CONCLUSIONS AND ORIGINAL CONTRIBUTION

5.1. CONCLUSIONS

Noncircular gears define a special class of mechanisms that, due to their advantages (reliability, high power transmission etc.), can successfully replace the traditional mechanisms (camshafts, transmission chains, belts etc.) for complex, variable motions. The main disadvantage of the noncircular gears, related to the high production costs, is not a current issue anymore, as the developments of software and manufacturing technologies have been achieved, and the noncircular gears are relaunched as an interesting topic for the researchers. Noncircular gears design, not following a standard algorithm, usually follows the two main steps: (i) the modelling of the conjugate centrodes and (ii) the teeth generating process.

This thesis is generally focused on the noncircular gears theory analysis, with the main purpose of generalizing the gears design procedure.

(i) For the conjugate centrodes modelling process, three hypotheses were considered, as mentioned in literature, as follows:

Hypothesis 1, *the instantaneous transmission ratio hypothesis*, assumes that the instantaneous transmission ratio variation and the centre distance are defined and the conjugate centrodes should be modelled, described by polar or Cartesian equations;

Hypothesis 2, *the driving centrode hypothesis*, assumes that the geometry of the driving centrode is defined and the centre distance, the conjugate centrode geometry and the transmission ratio should be determined;

Hypothesis 3, *the output motion hypothesis*, assumes that the driven centrode motion and centre distance are defined and gears centrodes geometries and the transmission ratio should be find out, respectively.

The above three algorithms were taken into account and an interactive website was designed in order to facilitate the noncircular conjugate centrodes modelling.

(ii) The second step within the noncircular gears design consists of the gears teeth generation.

The standard gears theory highlights two methods for the gears teeth generation, respectively: (i) the forming method, when the cutting tool profile is copied on the gear blank, requires the definition of **the gear base circle and the pressure angle** and (ii) the rolling method that requires **the gear pitch circle and the pressure angle** to be defined.

At the beginning, starting from the basic elements from the circular gears theory, the possibility of generating the noncircular gear teeth using the forming method was considered. Two hypotheses were proposed in order to generate the gear base curve: **CB1** hypothesis assumed that the base curve was the locus of the perpendicular segment end, from the gear centre to the current line of action, and **CB2** hypothesis assumed that the base curve was the locus of the curvature centre of the current standard involute that passed through the instantaneous centre of rotation. It was found out that, in both cases, the base curve geometry exhibited angular points, concave zones with high curvature, no proper to be set as a gear base curve. This remark led to the decision of not using the forming method while generating the noncircular gears teeth profiles.

In order to generate the teeth flanks profiles using the rolling method, an analytical method was developed, wherein the rolling of a standard rack cutter tooth along the noncircular pitch curve was described. For this purpose, two generating hypotheses were proposed:

(i) **Hypothesis 1 (IpGC1)** considered the accurate generation of the gear tooth flank, i.e. the rack-cutter pitch line, as tangent to the gear pitch curve, was permanently changing the direction during the rolling process. For arbitrary pitch curves, with convex-concave geometry, the tooth flank profile, named as **GCP profile** (correctly generated profile), is an arbitrary /unknown curve;

(ii) **Hypothesis 2 (IpGC2)** took into account an "approximate" generation of the tooth flank profile, considering the rolling of the rack-cutter tooth along the local osculating circle of the pitch curve. The tooth flank profile, named as **GCA profile** (approximately generated profile), is an involute of the local osculating circle.

The analytical approaches for the above mentioned generating hypotheses were the base of original PHP codes (Annex 6, Appendix 7) that enabled graphical representations of the gears pitch curves and teeth flanks profiles. A comparative analysis of the tooth flanks profiles geometries was also developed, for both generating hypotheses, highlighting the increase of tooth profile deviation of the GCA profile, compared to the GCP, in zones where the pitch curve curvature was high.

The PHP database was further imported to the AutoCAD environment and enabled to complete the gear section representation. Tooth addendum and dedendum were drawn as segments of tooth flank, limited by the addendum and dedendum curves, as offset curves to the gear pitch curve, at distance of m and $1,25m$, respectively, where the gear modulus m is not chosen at a standard value, it resulted from the pitch curve length and the gear number of teeth. The root fillet radius was considered as $0,38m$. Editing the noncircular gear section, the virtual solid models were built up by extrusion along the gear axis.

Based on the virtual models, generated by AutoCAD, noncircular gears were manufactured using a 3D printer Prusa I3 - 2 and the prototype was further used to build up an exhibition stand. The stand is equipped with a "step by step" motor and the Arduino Uno programmable circuit.

Also, the virtual models of the generated noncircular gears allowed further theoretical studies, focused on the specific gear performances, i.e. the static tooth contact pattern, using a controlled initial interference, and the FEM analysis. These studies were conducted using static and dynamic analyses. The influence of the teeth generating hypotheses and gear design parameters on the noncircular gears performances was analysed. It was shown that the gears generated by correct rolling exhibited higher performances, in terms of tooth static contact, compared to gears generated by approximate rolling. Also, higher values of the pressure angle improved tooth contact pattern, both on quantitative and qualitative aspects.

The static FEM analysis of the generated noncircular gears was developed by Autodesk Inventor, based on the gears solid models imported from AutoCAD. The gears bending behaviour highlighted the following:

- the gear correct generation led to improved gears meshing, both on convex and near linear areas, by reducing the maximum Von Mises stress and the maximum tooth displacement;
- for the concave areas, better stress behaviour was recorded for the gears generated by approximate method;
- the increase of the pressure angle leads to a better gears meshing, by reducing the maximum stresses and displacements.

The dynamic analysis of the gears meshing was also developed by Autodesk Inventor, based on solid models imported from AutoCAD. As the FEM dynamic analysis provided

information on the entire mechanism, an illustration of the critical areas was obtained, in terms of the gear stress and strain behaviour, i.e. the concave areas with maximum bending stress were highlighted, and convex areas, with high centrode radius or variable geometry, where high deformations occurred, where also highlighted. The results validated the above conclusions of static analysis, recommending a higher pressure angle and approximate generation for the gear teeth, in concave zones, in order to improve the noncircular gears mesh.

5.2. ORIGINAL CONTRIBUTIONS

Noncircular gears keep challenging the researchers from the gear industry, due to both their advantages, compared to traditional mechanisms, and developments of new design methods and manufacture process, resulted from the use of the advanced software and alternative technology.

The accomplishment of the thesis research objectives highlights the following original contributions:

- A literature survey concerning noncircular gears and the state-of-the-art of the research field;
- The noncircular conjugated centrodes modelling, using three generating hypotheses. The development of specific algorithms, accompanied by original PHP/HTML codes that enable the centrodes generation and graphic representations for the gear transmission ratio (Appendices 1, 2, 3);
- The development of an interactive website, available to specialists, for noncircular conjugated centrodes;
- The analysis of the possibility of generating the noncircular gears teeth using the forming method and the development of original PHP/HTML codes in case of two hypotheses assumed for determining and plotting the gear base curve: the hypothesis **CB1** (Appendix 4), which considers the base curve as the locus of the perpendicular segment end, from the gear centre to the current line of action, and **CB2** (Annex 5), which considers the base curve as the locus of the curvature centre of the current standard involute that passed through the instantaneous centre of rotation;
- The development of the computing algorithm and the PHP/HTML code required by the correct rolling method, applied for the gear teeth flanks profiles generation;
- The development of the computing algorithm and the PHP/HTML code required by the approximate rolling method, applied for the gear teeth flanks profiles generation;
- The development of an interactive website, available to specialists, for gears teeth profiles generation, in case of two hypotheses of rolling;
- The development of a comparative study regarding the teeth flanks geometries, generated by correct and approximate generation, in order to present the areas where high deviations are recorded for the tooth profile;
- The data organizing and import from PHP to AutoCAD, required for the further gear solids generation;
- The editing of the gears cross sections and the generation of the virtual models;
- The gears meshing simulation, in order to analyse the teeth static contact pattern, using a controlled interference and the AutoCAD environment. The study was focused on the teeth placed on concave, convex and near linear zones and highlights the influence the generating hypothesis and the gear pressure angle have on the teeth contact pattern area and distribution;

- The use of the FEM analysis for the generated noncircular gears. The study was performed using both static and dynamic analyses;
- The analysis of the influence the design data and the generating hypothesis have on the Von Mises stress and displacement for teeth selected from convex, concave and near linear zones;
- The dynamic gear meshing, performed in Inventor, and the dynamic FEM analysis that highlights the „critical” gear areas as regard the tooth stress and deflection. Also, the influence of the design data and the generating hypothesis on the gear meshing was analysed.

5.3. RESEARCH PERSPECTIVES

This paper proposes an original method for the noncircular gears generating process generalization. The gear generation is developed using a constant angular pitch and a constant pressure angle, in different generation hypotheses. In the future, the process of noncircular gears teeth generation can be enriched by different new approaches, using a constant pitch arc, varying the gear modulus, varying the pressure angle from one tooth to another etc.

Also, the gears meshing could be analysed to find out a method to evaluate of the gear ratio, to predict the evolution of the line of action, to present the influence the centre distance variation and the misalignment have on the gears performances etc.

The exhibition stand could be used for further experimental tests, developing a comparative study on the noncircular gears efficiency, related to frequency converters.

Lastly, it is important to find out industrial applications and to design the proper noncircular gears that would generate the required variable motion.

LIST OF PAPERS

BDI

1. Cristescu B., Cristescu A., Andrei L., *Algorithms For Noncircular Gear Pitch Curves Generation*, 2014, Applied Mechanics and Materials, Vol. 658, pag 41-46, Trans Tech Publications Ltd, ISSN: 1662-7482
2. Cristescu B., Cristescu A., Andrei L., *Analytical generation of involute flanks of noncircular gear tooth*, 2014, The Annals of "Dunarea de Jos" University of Galati, Mathematics, Physics, Theoretical Mechanics, Fascicle II, Year VI (XXXVII), no. 1, pag. 36-43, Galati University Press
3. Cristescu A., Cristescu B., Andrei L., *Generalization of Multispeed Gear Pitch Curves Design*, 2014, Applied Mechanics and Materials, Vol. 659, pag. 559-564, Trans Tech Publications Ltd, ISSN: 1662-7482
4. Cristescu A., Cristescu B., Andrei L. – *Finite Element Analysis of Multispeed Noncircular Gears*, Applied Mechanics and Materials, Vol. 808, pag. 246-251, Trans Tech Publications Ltd
5. Cristescu B., Andrei L., Cristescu A. – *Contact Analysis for Noncircular Gears*, 2015, The Annals of "Dunarea de Jos" University of Galati, Technologies in Machine Building, Fascicle V, Galati University Press, ISSN: 1221-4566
6. Cristescu A., Andrei L., Cristescu B. - *Influence of tooth profile on the noncircular gear tooth contact*, 2016, ROTRIB 2016, Galați – Lucrare acceptată

ISI Proceedings

7. Cristescu A., Cristescu B., Andrei L., *Designing Multispeed Gear Pitch Curves*, 2014, Applied Mechanics and Materials, Vol. 657, pag. 480-484, Trans Tech Publications Ltd, ISSN: 1662-7482

Oral and poster papers presented at national conference

8. Cristescu B., Cristescu A., Andrei L., *Algorithms for Conjugate Noncircular Centrodes Generation*, Conferința Națională de Comunicări Științifice Studentești „Anghel Saligny”, Galați, 2013;
9. Cristescu B., Andrei L., *Analytical generation of involute flanks of noncircular gear tooth*, Conferința Națională de Comunicări Științifice Studentești „Anghel Saligny”, Galați, 2014;
10. Cristescu B., Andrei L., *Influence of Tooth Profile Generation on Noncircular Gear Contact*, Conferința Internațională BALKANTRIB, Sinaia, 2014;
11. Cristescu B., Andrei L., *Generating and meshing noncircular gears*, Scientific Conference of Doctoral Schools from UDJ, Galați, 2015
12. Cristescu A., Cristescu B., Andrei L., *Synthesis of Noncircular Gear Pitch Curves Design*, Conferința Națională de Comunicări Științifice Studentești „Anghel Saligny”, Galați, 2013;
13. Cristescu A., Cristescu B., Andrei L., *Multispeed Gears*, Expoziția UGAL INVENT, Galați, 2014.

Bibliography

- [1] M. Vasie, *Cercetări privind roțile dințate cu transmitere variabilă a mișcării*, Universitatea "Dunărea de Jos" Galați, 2012.
- [2] A. Cristescu, *Angrenaje necirculare. Cercetări privind angrenajele necirculare cu lege de mișcare impusă*, Universitatea „Dunărea de Jos” Galați, 2015.
- [3] <http://kmodll.library.cornell.edu/bip.php>.
- [4] E. Mikhailov, V. Tarabarin, *Models of the Gearing Drives With Variable Gears Ratio in the Collection of Bauman Moscow State Technical University*, 13th World Congress in Mechanism and Machine Science, Guanajuato, Mexico, 2011.
- [5] B. Laczik, *Involute Profile of Non-Circular Gears*, Inst. Mech. Eng. Coll. Dunaújváros, no. 1, pp. 1–5, 2004.
- [6] E. R. Fellows, *Gear generating cutting machine*, [Brevet]: 1516524, SUA, 1922
- [7] G. m. b. H. Boop & Reuther, *Improvements in or relating to milling toothed gears* [Brevet]: DE668897, 1938.
- [8] F. L. Litvin ș.a., *Noncircular Gears. Design and Generation*, Cambridge University Press, 2009.
- [9] H. F. Quintero Rianza ș.a., *The Synthesis of an N-Lobe Noncircular Gear Using Bézier and B-Spline Nonparametric Curves in the Design of Its Displacement Law*, Journal of mechanical design, 129 (2007) 981-985..
- [10] B.-W. Bair ș.a., *Mathematical Model and Characteristic Analysis of Elliptical Gears Manufactured by Circular-Arc Shaper Cutters*, Journal of mechanical design, 129 (2007) 210-214.
- [11] M. Vasie, L. Andrei, "Noncircular Gear Design And Generation By Rack Cutter," The Annals of Dunarea Jos University of Galati, Fascicle V, 1 (2011) 69-74.
- [12] B. Bloomfield, *Noncircular gears*, Product Engineering Special Report, pg. 158–165.
- [13] G. A. Danieli, D. Mundo, *New developments in variable radius gears using constant pressure angle teeth*, Mechanism and machine theory, 40 (2005) 203–217.
- [14] L. Andrei, M. Vasie, *Noncircular Gears Designed by Geometric Hypothesis*, Applied Mechanics and Material, 657 (2014) 684–688.
- [15] G. F. Baer, *New Synthesis Method For Non-Circular Gears*, Technische Univesitaet Dresden, Germany.
- [16] M. Vasie, L. Andrei, A. Cristescu, *A brief synthesis of noncircular gears*, Constanta Maritime University Annals, 16 (2011) 191–195.
- [17] B. Cristescu, A. Cristescu, L. Andrei, *Algorithms for Noncircular Gear Pitch Curves Generation*, Applied Mechanics and Materials, 658 (2014) 41–46.
- [18] P. Fanghella, *Kinematic synthesis and design of non-circular gears through a symbolic-numeric modeling approach*, Proceedings of IDETC/CIE, Long Beach, California, 2005.
- [19] L. Kowalczyk, S. Urbanek, *The geometry and kinematics of a toothed gear of variable motion*, Mechanism and Machine Theory, 11 (3) (2003) 60–62.
- [20] C.F.Carr, *Method of making a modified elliptical gear*, [Brevet]. US 5545871 A, 1996.
- [21] <http://kmoddl.library.cornell.edu/index.php>
- [22] F. L. Litvin ș.a., *Tandem design of mechanisms for function generation and output speed variation*, Comput. Methods Appl. Mech. Eng., 198 (2009) 860–876.

- [23] R. Zhang, X. Wu, *Design of noncircular gears with discontinuous pitch curve*, *Chinese J. Mech. Eng.*, 19 (2006) 594–599.
- [24] F. Freudenstein, *Intermittent motion mechanism employing noncircular gears*, [Brevet]: 1969.
- [25] D. B. Dooner, A. Palermo, D. Mundo, *An Intermittent Motion Mechanism Incorporating a Geneva Wheel and a Gear Train*, *Transactions of the Canadian Society for Mechanical Engineering*, 38 (3) (2014) 359–372.
- [26] J. Doric ş.a., *One Approach for Modelling Intermittent Motion Mechanism with Noncircular Gears*, *Machine Design.*, 3 (2) (2011) 121–126.
- [27] S.-H. Gu, Q. Geng, *Design and application of elliptic gear in the geneva mechanism*, *Journal of Machine Design*, 8 (2009) 121-126.
- [28] C. Guo ş.a., *Design of the pitch curves of noncircular gears for quick return mechanism*, *Chinese J. Mech. Eng.*, 41 (2005) 221–227.
- [29] D. B. Dooner, *Function generation utilizing an eight-link mechanism and optimized non-circular gear elements with application to automotive steering*, *Proceedings of the Institution of Mechanical Engineers*, 215 (2001) 847–858.
- [30] K.-Y. Bae and Y.-S. Yang, “Design of a non-circular planetary-gear-train system to generate an optimal trajectory in a rice transplanter,” *J. Eng. Des.*, vol. 18, no. 918910199, pp. 361–372, 2007.
- [31] J.-Y. Liu, S.-L. Chang, D. Mundo, *Study on the use of a non-circular gear train for the generation of Figure-8 patterns*, *Proceedings of the Institution of Mechanical Engineers, Part E: Journal of Process Mechanical Engineering*, 220 (2006) 1229–1236.
- [32] M. S. Harshe, *Design of One Degree of Freedom Closed Loop Spatial Chains Using Non-Circular Gears*, *Lucrare de disertație*, 2009.
- [33] E.-C. Lovacs ş.a., *Non-circular gear wheels in the geared-linkages mechanisms*, 12th IFToMM World Congress, 2007.
- [34] K. H. Modler ş.a., *General method for the synthesis of geared linkages with non-circular gears*, *Mech. Mach. Theory*, 44 (2009) 726–738.
- [35] J. S. A. I. Praneeth ş.a., *Design of whitworth quick return mechanism using non-circular gears*, *International Journal of Mechanical and Production Engineering*, 2(6) (2014) 59–64
- [36] D. Mundo, G. Gatti, D. B. Dooner, *Optimized five-bar linkages with non-circular gears for exact path generation*, *Mechanism and Machine Theory*, 44 (4) (2009) 751–760.
- [37] D. Mundo, G. Gatti, *A graphical-analytical technique for the synthesis of non-circular gears in path-generating geared five-bar mechanisms*, *Transactions of the Canadian Society for Mechanical Engineering*, 32 (3) (2008) 487–497.
- [38] D.-J. Yu, *The design of drive mechanism for precision press based on non-circular gears*, *Modular Machine Tool & Automatic Manufacturing Technique*, 12, 2010.
- [39] Y.-A. Yao, H.-S. Yan, *A new method for torque balancing of planar linkages using non-circular gears*, *Proceedings of the Institution of Mechanical Engineers, Part C: Journal of Mechanical Engineering Science*, 2003.
- [40] A. Kitano, *Elliptic gear wheel*, [Brevet]. US 4036073 A, 1977.
- [41] H. Katory, *Planetary gear having non-circular gears*, [Brevet.] US 4788891 A, 1988.
- [42] A. Takami, *Rotary pump having alternating pistons controlled by non-circular gears*, [Brevet]. US 4872818 A, 1989.
- [43] T. Takara, A. Takami, *Non-circular gear pair*, [Brevet]. US 5251507 A, 1993.
- [44] T. Yokoyama, *Powder molding press*, [Brevet]. US 5547360 A, 1996.
- [45] E. Doedje s.a., *Drive apparatus for a forming machine*, [Brevet]. US 6289754 B1, 2001.

- [46] E. Ottaviano, D. Mundo, G. A. Danieli, M. Ceccarelli, *Numerical and experimental analysis of non-circular gears and cam-follower systems as function generators*, Mechanism and machine theory, 43 (2008) 996–1008.
- [47] J.L.Coleman s.a., *Articulated hinges using non-circular gears*, [Brevet]. US 8186781 B2, 2012.
- [48] J. J.P. Nolta, *Constant to variable gear pitch for temperature door rotation*, [Brevet]. WO 2003004843 A1, 2014.
- [49] P.A. Johnson, *Integral pump and flow meter device*, [Brevet]. US 5704767 A, 1998.
- [50] B.D. Comiski s.a., *Chemical dispensing systems and positive displacement flow meters*, [Brevet]. US 20110031272 A1, 2011.
- [51] A. Skiroda, R. Mehus, *Fluid flow meter*, [Brevet]. US 8166828 B2, 2012.
- [52] W.D. Flavelle, *Elliptical gear pump fluid driving apparatus*, [Brevet]. AF04C214FI, 2014.
- [53] M. Yazar, A. Ozdemir, *Comparative analysis of the pressure variations and the flow rates of a hydraulic pump made of a pair of elliptical and cylindrical spur gears*, Tehnology, 14 (1) (2011) 1–10.
- [54] F. Freudenstein, C.-K. Chen, *Variable-Ratio Chain Drives With Noncircular Sprockets and Minimum Slack-Theory and Application*, Journal of mechanical design, 131 (1991) 253 - 262.
- [55] D. Mundo, *A transmission mechanism for pedal vehicules using non-circular gears*, [Brevet]. WO 2006038241 A1, 2006.
- [56] D. B. Dooner, *Use of Noncircular Gears to Reduce Torque and Speed Fluctuations in Rotating Shafts*, Journal of mechanical design, 119 (1997) 299-306.
- [57] T.M.C.O.B. MURAJI, *Drive device with non-circular gear*, [Brevet]. EP 1329618 A1, 2003.
- [58] B. Librosvich, R. W. Tucker, C. Wang, *On Gear Modelling in Multistage Rotary Vane Engines*, Meccanica, 39 (2004) 47–61.
- [59] T. Emura, A. Arakawa, *A new steering machanism using noncircular gears*, Japan Society of Mechanical Engineering, 35 (1992) 604–610.
- [60] M. Sakita, *Mechanism for interconnecting first- and second-shafts of variable speed rotation to a third shaft*, [Brevet]. US6457452, 2003.
- [61] J.H. Kerr, *All gear infinitely variable transmission*, [Brevet]. US 6849023 B1, 2005.
- [62] F. Tsay, Z. H. Fong, *Study on the generalized mathematical model of noncircular gears*, Mathematical and computer modelling, 41 (2005) 555–569.
- [63] D. Mundo, *Geometric design of a planetary gear train with non-circular gears*, Mechanism and machine theory, 41 (2006) 456–472.
- [64] M. Vasie, L. Andrei, *“Design And Generation Of Noncircular Gears With Convex-Concave Pitch Curves,”* The Annals of Dunarea Jos University of Galati, Fascicle V (2012) 55–60..
- [65] M. Vasie, L. Andrei, *“Noncircular Gear Design And Generation By Rack Cutter,”* The Annals of Dunarea Jos University of Galati, Fascicle V, 1 (2011) 69-74.
- [66] L. Andrei, M. Vasie, *Using supershape in noncircular gear centrode modeling process*, Annals of Dunarea Jos University of Galati, Fascicle II, 2 (2010) 259-266.
- [67] M. Vasie, L. Andrei, D. Mundo, *General model for internal mating centrodes of noncircular gears*, The Annals of Dunarea Jos University of Galati, Fascicle II, 2 (2011) 183-190.
- [68] J. Yan, D. C. H. Yang, S.-H. Tong, *On the Generation of Analytical Noncircular Multilobe Internal Pitch Curves*, Journal of mechanical design, 130 (2008) 092601-1-092601-7.

- [69] S.-H. Tong, D. C. H. Yang, *Generation of Identical Noncircular Pitch Curves*, Journal of mechanical design, 120 (1998) 337-341.
- [70] D. C. H. Yang, S.-H. Tong, J. Lin, *Deviation-Function Based Pitch Curve Modification for Conjugate Pair Design*, Journal of mechanical design, 121 (1999) 579-583.
- [71] B. Laczik, *Design and Manufacturing of Non-Circular Gears by Given Transfer Function*, Proc. ICT, (2007) 101–109.
- [72] D. Mundo, G. Gatti, D. B. Dooner, *Combined synthesis of five-bar linkages and non-circular gears for precise path generation*, 12th IFToMM World Congress, 2007.
- [73] J. R. Mckinley ş.a., *Planar Motion Generation Incorporating a 6-Link Mechanism and Non-Circular Elements*, ASME 29th Mechanism and Robotics Conference (2005) 1–12.
- [74] J. R. Mckinley ş.a., *Three-Dimensional Rigid Body Guidance using Gear Connections in a Robotic Manipulator with Parallel Consecutive Axes*, Lucrare de disertație, 2007.
- [75] G. A. Danieli, *Toward a greater industrial application of variable radius gearing*, 12th IFToMM World Congress, Besancon, France, 2007.
- [76] L. Dawei, R. Tingzhi, *Study on Deformed Limacon Gear and Motion Optimization of Its Serial Mechanism*, Journal of mechanical design, 133 (2011) 061004-1-061004-8.
- [77] J. Liu, Y. Chen, *A Design for the Pitch Curve of Noncircular Gears with Function Generation*, Proceedings of the International MultiConference of Engineers and Computer Scientists, II(2) (2008) 19–21.
- [78] M. Okada, Y. Takeda, *Optimal design of nonlinear profile of gear ratio using non-circular gear for jumping robot*, Proceedings IEEE Int. Conf. Robot. Autom., (2012) 1958–1963.
- [79] G. Figliolini, J. Angeles, *Synthesis of the Base Curves For N-Lobed Elliptical Gears*, Journal of mechanical design, 125 (2005) 997-1005.
- [80] A. Lozzi, *Non-circular gears-graphic generation involutes and base outlines*, Proceedings of the Institution of Mechanical Engineers, 214 (2006).
- [81] F. L. Litvin ş.a., *Generation of planar and helical elliptical gears by application of rack-cutter, hob, and shaper*, Comput. Methods Appl. Mech. Eng., 196 (2007) 4321–4336.
- [82] F. L. Litvin ş.a., *Design and investigation of gear drives with non-circular gears applied for speed variation and generation of functions*, Comput. Methods Appl. Mech. Eng., 197 (2008) 3783–3802.
- [83] .-L. Chang, C.-B. Tsay, *Computerized Tooth Profile Generation and Undercut Analysis of Gears Manufactured With Pre-Shaving Hobs*, Appl. Mech. Mater., 16–19 (1996) 1278–1282.
- [84] G. Figliolini, J. Angeles, *The Synthesis of Elliptical Gears Generated by Shaper-Cutters*, Journal of mechanical design, 125 (2003) 793-801.
- [85] H. F. Quintero ş.a., *An analytical model for the tooth profile generation of noncircular gear*, 12th IFToMM World Congress, 2007.
- [86] H. F. Quintero, *Thermodynamic and dynamic analysis of an internal combustion engine with a noncircular-gear based modified crank-slider mechanism*, 12th IFToMM World Congress, (2007), France.
- [87] J. Xia ş.a., *Noncircular Bevel Gear Transmission With Intersecting Axes*, J. Mech. Des., 130 (2008) 545-551.
- [88] B. W. Bair, *Computer aided design of elliptical gears with circular-arc teeth*, Mechanism and Machine Theory, 39 (2004) 153–168.
- [89] B. W. Bair ş.a., *Tooth profile generation and analysis of oval gears with circular-arc teeth*, Mech. Mach. Theory, 44 (2009) 1306–1317.
- [90] S.-L. Chang, C.-B. Tsay, *Computerized Tooth Profile Generation and Undercut Analysis of Gears Manufactured With Pre-Shaving Hobs*, Appl. Mech. Mater., 16–19 (1996) 1278–1282.

- [91] J. Li ş.a., *Numerical computing method of noncircular gear tooth profiles generated by shaper cutters*, The international journal of advanced manufacturing technology, 33 (2007) 1098–1105.
- [92] G. A. Danieli, *Analytical Description of Meshing of Constant Pressure Angle Teeth Profiles on a Variable Radius Gear and its Applications*, Journal of mechanical design, 122 (2000) 203-217.
- [93] B. Laczik ş.a., *A New Approach for Designing Gear Profiles using Closed Complex Equations The Method of Gear Profile Generation*, Acta Polytechnica Hungarica, 11 (6) (2014) 159–172.
- [94] S. Gao ş.a., *Design and analysis of shapes of elliptic gears*, 12th International Conference on Geometry and Graphics, 2006.
- [95] I. Zarebski, T. Salacinski, *Designing of non-circular gears*, The archive of mechanical engineering, LV (2008) 275–292.
- [96] C. Lin, *Design and Manufacture of Noncircular Bevel Gears*, 13th World Congress in Mechanism and Machine Science, Guanajuato, Mexico, 2011.
- [97] L. Jing, *A Pressure Angle Function Method for Describing Tooth Profiles of Planar Gears*, Journal of mechanical design, 131 (2009) 051005-1 - 051005-8.
- [98] Y. Zhao, *Planar unfolding algorithm of noncircular bevel gears*, China Mech. Eng., 19 (17) (2008) 2046–2049.
- [99] . Li, *Effects of machining errors, assembly errors and tooth modifications on loading capacity, load-sharing ratio and transmission error of a pair of spur gears*, Mechanism and Machine Theory, 42 (2007) 88–114.
- [100] S. Li, *Effect of addendum on contact strength, bending strength and basic performance parameters of a pair of spur gears*, Mechanism and Machine Theory, 43 (2008) 1557–1584.
- [101] R. Cioară, C. Pisarciuc, *Danturi necirculare și mașini de danturat pe contur necircular*, Braşov, Editura Universităţii, 2001.
- [102] R. Cioară, *Simplificarea structurii cinematice a mașinilor-unelte – cerință în sprijinul dezvoltării durabile*, REGENT, 10 (1) (2009) 18-27.
- [103] V. A. Vanin, A. N. Kolodin, *Kinematic structure of gear-cutting machine tools based on a hydraulic step drive for the production of noncircular gears*, Russian Engineering Research, 29 (3) (2009) 291–297.
- [104] A. Cristescu, B. Cristescu, L. Andrei, *Designing Multispeed Gear Pitch Curves*, Applied Mechanics and Materials, 657 (2014) 480–484.
- [105] A. Cristescu, B. Cristescu, L. Andrei, *Generalization of Multispeed Gear Pitch Curves Design*, Applied Mechanics and Materials, 659 (2014) 559–564.
- [106] D. Powers, *PHP Object-Oriented Solutions*. Editura APress, 2008.
- [107] L. Welling, L. Thomson, *Dezvoltarea aplicațiilor Web cu PHP și MySQL*. Editura Teora, 2005.
- [108] S. Holzner, *Inițiere în PHP 5*. București: Editura Teora, 2005.
- [109] P. Volkerding, K. Reichard, *Linux Configuration & Installation*. BPB Publications, 1997.
- [110] M. Gafițeanu, *Organe de mașini*. București: Editura Tehnică, 1980.
- [111] A. Epureanu, O. Pruteanu, I. Gavrilaş, *Tehnologia Construcției de Mașini*. EDP, 1983.
- [112] V. Constantin, V. Palade, *Mecanisme și Organe de Mașini*. Editura Fundației Universitare "Dunărea de Jos", 2005.
- [113] -, *Mică enciclopedie matematică*. Editura tehnică - București, 1980.
- [114] V. Palade, N. Diaconu, *Organe de mașini*. Galați: Galați University Press, 1995.
- [115] H. F. Q. Riaza, ş.a., *Study of the Base Curve and Formation of Singular Points on the Tooth Profile of Noncircular Gears*, J. Mech. Des., 129 (2007) 538 - 543.

- [116] B. Cristescu, L. Andrei, A. Cristescu, *Analytical generation of involute flanks of noncircular gear tooth*, The Annals of Dunarea Jos University of Galati, Fascicle II, 1 (2014) 104-110.
- [117] R. Alagaraja, *An Overview of Gear Manufacturing Processes*, 2010
- [118] <http://www.cm.tuiasi.ro/docs/Danturarearotilordintate.pdf>
- [119] G. Rădulescu s.a., *Îndrumar de proiectare în construcția de mașini*. București: Editura Tehnică, 1986.
- [120] http://webbut.unitbv.ro/Carti%20on-line/TM/Capitolul_1.pdf, ANGRENAJE, pp. 9 – 110.
- [121] M. M. Popovici, *Mecanica tehnică pentru muncitori - Dinamica și aplicațiile ei tehnice*. București: Editura Tehnică, 1985.
- [122] G. Buicliu ș.a., *Manualul inginerului*. București: Editura Tehnică, 1955.
- [123] D. Singh, M. Suhaib, *Kinematic Considerations in Gear Drives - A Review*, International Journal of Innovative Research in Science Engineering and Technology, 3 (1) (2014) 8204–8214.
- [124] D. B. Dooner, *Kinematic geometry of gearing*. John Wiley & Sons, Ltd., 1988.
- [125] G. Figliolini, P. Rea, *Effects of the design parameters of involute gears generated by rack-cutters*, International Gear Conference, Lyon, 2014.
- [126] L. Liu, Z. H. Zhou, *Smooth and non-smooth contact analysis of micro-surface of gear teeth*, International Gear Conference, Lyon, 2014.
- [127] A. Toso, G. H. K. Heirman, D. Mundo, *A comparison and experimental validation of gear contact models for spur and helical gears*, International Gear Conference, Lyon, 2014.
- [128] A. Cristescu, L. Andrei, M. Niculescu, *The Influence of Kinematics Variation on Multispeed Gears Meshing*, Applied Mechanics and Materials.
- [129] B. Cristescu B., L. Andrei, A. Cristescu – *Contact Analysis for Noncircular Gears*, The Annals of “Dunarea de Jos” University of Galati, Technologies in Machine Building, Fascicle V, Galati University Press, (2015) ISSN: 1221-4566
- [130] S. Khan, *Simulation And Analysis Of Transmission Error In Helical Non Circular Model*, International Journal of Mechanical Engineering and Technology, 6 (2) (2015) 128-136.
- [131] D. Barkah ș.a., *3D Mesh Generation for Static Stress Determination in Spiral Noncircular Gears Used for Torque Balancing*, Journal of mechanical design, 124 (2002) 313-321.
- [132] S. Li, *Finite element analyses for contact strength and bending strength of a pair of spur gears with machining errors, assembly errors and tooth modifications*, Mechanism and Machine Theory, 42 (2007) 698–726.
- [133] G. Buzdugan, A. Seleșteanu, *Manualul inginerului mecanic*. București: Editura Tehnică, 1959.
- [134] A. Tudor, *Organe de mașini – Note de curs partea a II-a*, 2004. [Online]. http://www.omtr.pub.ro/didactic/om_isb/om2/om2.pdf. [Accesat: 15-May-2014].
- [135] I. D. Filipoiu, A. Tudor, *Proiectarea transmisiilor mecanice*. București, 2006.
- [136] A. Davidescu, ș.a., *Manualul inginerului*. București: Editura Tehnică, 1955.
- [137] G. Buzdugan, *Rezistența materialelor*. București: Ed. Academiei R.S.R., 1986.
- [138] F. Redell, *Understanding and Applying FEA*, 2008.
- [139] L. S. Hansen, *Learning and applying Autodesk Inventor 2010 step by step*. Industrial Press Inc., 2009.
- [140] C. Stăncescu, *Modelare parametrică și adaptivă cu Inventor*. București: FAST, 2014.
- [141] T. Tremblay, *Autodesk Inventor 2012 and Inventor LT 2012 Essentials*. John Wiley & Sons, Ltd., 2011.
- [142] T. Bousfield, *A practical Guide to AutoCAD AutoLISP*. Ed. Longman, 1998.
- [143] G. Omura, B. C. Benton, *Mastering AutoCAD 2014 and AutoCAD LT 2014*. 2013.

