

**A NOVAL COMPARISON OF CLASS D AND CLASS E INVERTER BASED
HIGH FREQUENCY APPLICATION**

S.Arumugam¹ and S.Rama Reddy²

1. *Research Scholar, Bharath University, Chennai, India.*

s_arumugam@rediffmail.com

2. *Professor Jerusalem College of Engg Chennai, India.*

srr_victory@yahoo.com

Abstract: This paper deals with the simulation and implementation of class E inverter based induction heater system. Class E inverter is analyzed; simulated and implemented. Utility frequency AC Power is converted into high frequency AC power using class E inverter. This high frequency AC is used for induction heating. Open and closed loop systems are modeled and they are simulated using Matlab Simulink. The results of simulation and implementations are presented. The laboratory model is implemented and the experimental results are obtained. These Experimental results are correlated with the simulation results.

Keywords: High Frequency Inverter, Induction Heating Heating (IH), Push-Pull Amplifier, Zero Voltage Source (ZVS), Simulink.

1. INTRODUCTION

INDUCTION HEATING is a non-contact process. It uses high frequency electricity to heat materials that are electrically conductive. Since it is non-contact, the heating process does not contaminate the material that is being heated. It is also very efficient since the heat is actually generated inside the work piece. This can be contrasted with other heating methods where heat is generated in a flame or heating element which is then applied to work piece. For these reasons induction heating lends itself to some unique application in industry. The development of high-frequency induction power supplies provided a means of using induction heating for surface hardening. The early use of induction involved trial and error with built-up personal knowledge of specific applications, but a lack of understanding of the basic principles. Throughout the years the understanding of the basic principles has been expanded extending currently into computer

modeling of heating applications and processes. Knowledge of these basic theories of induction heating helps to understand the application of induction heating as applied to induction heat treating. Induction heating occurs due to electromagnetic force fields producing an electrical current in a part. The parts heat due to the resistance to the flow of this electric current.

A high-frequency class-D/Class E inverter has become very popular and is more and more widely used in various applications. It must be effectively selected according to the applications in order to meet the inverter requirements under a high-frequency switching operation due to load specifications. In addition, one of the main advantages of the class-D inverter is low voltage across the switch, which is equal to the supply voltage. Thus, compared with other topologies (class-E quasi-resonant inverter, etc.) for IH applications, the class-D/Class-E inverter is suited for high-voltage applications [1] and pulse-amplitude modulation

(PAM) to control the output power [5], [6]. Between them, frequency modulation control is the basic method that is applied against the variation of load or line frequency. However, frequency modulation control causes many problems since the switching frequency has to be varied over a wide range to accommodate the worst combinations of load and line. Additionally, in case of operation below resonance, filter components are large because they have to be designed for the low-frequency range. In addition, it is apt to audible noise when two or more inverters are operated at the same time with different switching frequencies.

Besides, the soft-switching operating area of the zero-voltage switching (ZVS)–PFM high-frequency inverter is relatively narrow under a PFM strategy. Keeping the constant switching frequency and controlling the output power by pulse width modulation (PWM) are obvious ways to solve the problems of variable-frequency control. Therefore, class-D-inverter topologies using a PWM chopper at the input, phase-shifted PWM control, PWM technique, pulse width modulation–frequency modulation (PWM–FM) technique, current-mode control, and a variable resonant inductor or capacitor have been proposed [7]–[11], [12].

The constant-switching-frequency operation supposes that each inverter in the applications is operating at the same frequency, making it necessary to control power without frequency variations, and this is highly desired for the optimum design of the output smoothing and noise filters. However, these control requirements and operating characteristics have considerable complexity due to the fixed switching frequency, which limits their performance [12]. In addition, if the system is operated with phase-shifted PWM control, the ZVS is not achieved at light load [13], [14]. To simplify output-power control, a full bridge zero-current switching (ZCS)–pulse-density modulation (PDM) class-D inverter is proposed [15].

The output power of the ZCS–PDM class-D inverter can be controlled by adjusting the pulse density of the square-wave voltage. However, when the output is controlled by the pulse density, like that in [15], the load current should be freewheeled, and then, the output voltage of the inverter becomes zero. As a result, the conduction losses of the inverter are caused by the freewheeling current during the freewheeling mode. Therefore, to solve these problems, this paper deals with a simple power-control scheme of constant frequency variable power (CFVP) for the class-D inverter in the IH-jar application without additional devices.

When the class-D inverter operates at a fixed switching frequency that is higher than its resonant frequency, it can maintain ZVS operation in the

whole load range. Thus, the switching losses and electromagnetic interference (EMI) are decreased. In addition, by adjusting the duty cycle of fixed low frequency, the output power is simply controlled in a wide load and line range. The advantages of a new power-control scheme are simple configuration and wide power-regulation range. It is easy to control the output power for wide load variation. In addition, the switches always guarantee ZVS from light to full loads, and a filter is easy to design by using the constant switching frequency.

The proposed power-control scheme and principles of the class-D inverter are explained in detail. The theoretical analysis, simulation, and experimental results verify the validity of the class-D inverter with the proposed power-control scheme.

2. PRINCIPLE OF OPERATION

2.1. Class-D Series Resonant Inverter

A class-D inverter will be generally used to energize the induction coil to generate high-frequency magnetic induction between the coil and the cooking vessel, consequently, high-frequency eddy current, and, finally, heat in the vessel bottom area. The class-D inverter takes the energy from the input source.

The dc voltage is converted again into a high-frequency ac voltage by the class-D inverter. Then, the inverter supplies a high-frequency current to the induction coil. Fig.1. shows the class-D inverter system of IH jar. The class-D inverter consists of two switches $S1$ and $S2$ with antiparallel diodes $D1$ and $D2$, two resonant capacitors $Cr/2$, and an induction coil that consists of a series combination of equivalent resistance R_{eq} and inductance L_{eq} . The dc input voltage is directly supplied into an inverter. Then, ($S1, D1$), and ($S2, D2$) are alternately used to administer a high-frequency current to the induction coil. In particular, two switches are operated at square wave with suitable dead time between the two driving commands.

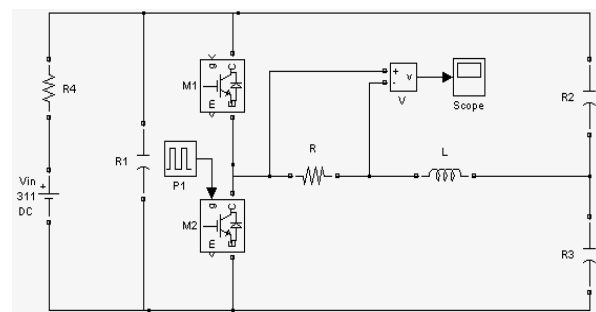

Fig.1. Class-D inverter system

The class-D inverter is operated above the resonant frequency, which means that the switches are turned on with ZVS.

2.2. Push Pull Class-E Inverter

The basic schematic of the proposed push-pull Class-E series- parallel LCR resonant PA is shown in Fig. 2. It contains two MOSFETs, two inductors, two capacitors, and a load resistance.

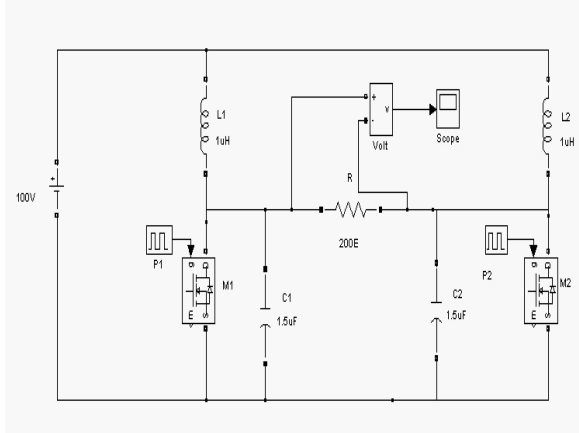

Fig.2. Basic push pull class- E power amplifier

Switches S1 and S2 are complementarily activated to drive periodically at the operating frequency $f = \omega/2\pi$ as in a push-pull switching PA[10],[11],[13], i.e., the switch waveforms are identical, except that the phase shifts between S1 and S2 are π with an “on” duty ratio D of less than 50%.

The simplest type of half-amplifier is a series-parallel resonant circuit, which consists of an inductor L in series with a paralleled capacitor C and resistor R. The resistor R_L is the load to which the AC power is to be delivered, with neither end connected to a ground. It is suitable for a load that is balanced to a ground, but most RF-power loads have one end connected to a ground. To accommodate grounded loads, the proposed topology needs to add one of the following: a balun that can be used to provide the interface with the amplifier [14][15][18]; or a two-winding transformer (that has V_i connected to a center-tap on the primary winding), between the grounded load (on the grounded secondary winding) and the drains of S1 and S2 (connected to the ends of the center-tapped primary winding). To reduce the transistor turn-on power losses, the switch current i_s increase gradually from zero after the switch is closed. The proposed push-pull Class-E PA[16][19] uses a pair of LC resonant networks with an overlapped capacitor-voltage waveform; this offers additional degrees of freedom.

3. SIMULATION RESULTS

The Class D/E inverter systems are simulated and the results are presented here. Class D inverter circuit is as shown in Fig 3.a. Scopes are connected to measure the voltages. DC input voltage is shown in Fig.3.b.

Driving pulse for switch 1 and switch 2 are shown in Fig.3.c. Output Current & Voltage waveforms are shown in Figs.3.d. and 3.e. respectively.

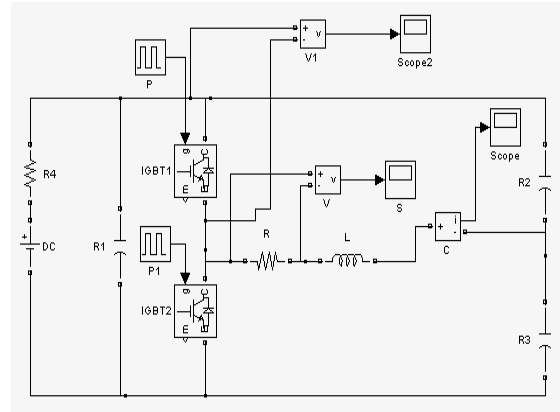

Fig.3.a. Matlab circuit diagram of Class D Inverter

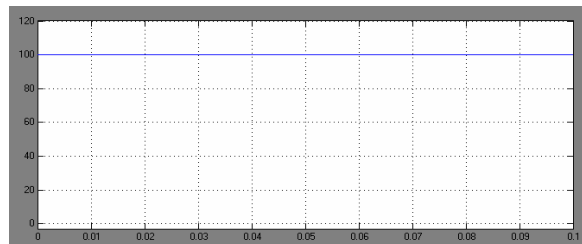

Fig.3.b. Dc Input voltage

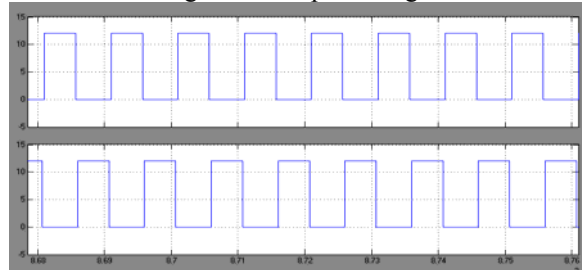

Fig.3.c. Driving pulses

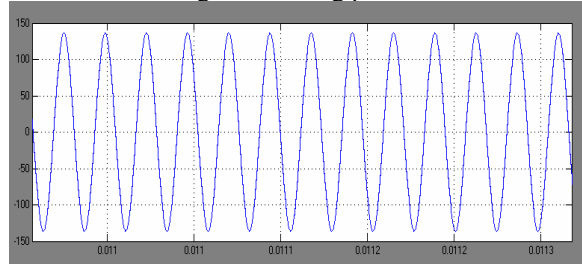

Fig.3.d. Output Current

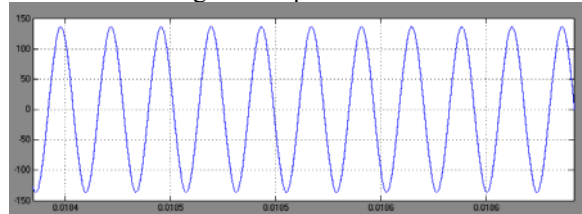

Fig3.e. Output Voltage

Open loop system with a disturbance at the input is shown in Fig.4.a. A step change in input voltage is applied as shown in Fig.4.b. The output of the rectifier is shown in Fig.4.c. The output of the class D inverter is shown in Fig 4. d. It can be seen that there is an increase in the output when there is a disturbance at the input.

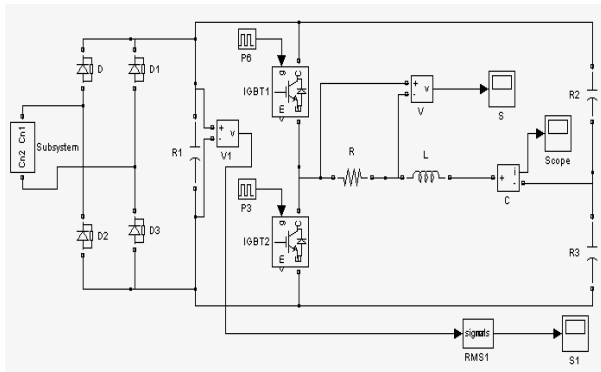

Fig.4.a Open loop system

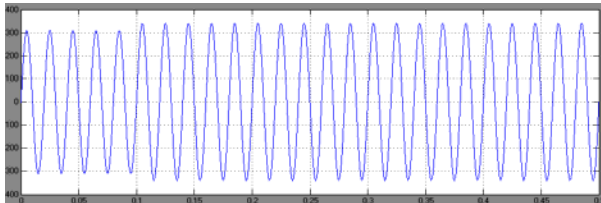

Fig.4.b. Input Voltage.

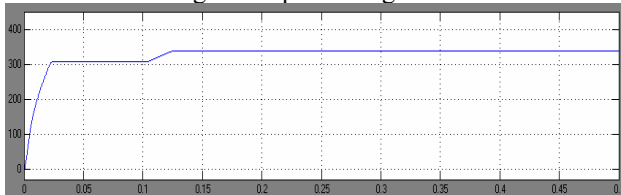

Fig.4.c. Rectifier output Voltage.

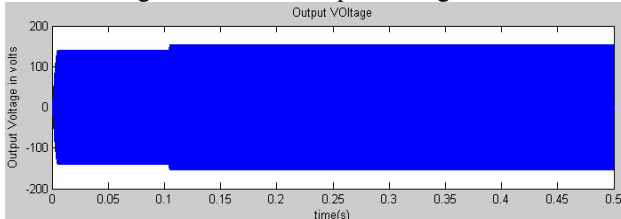

Fig.4.d. Output Voltage

Closed loop circuit model is shown in fig.4.e. Dc voltage is sensed and it is compared with the reference value. The output of the PI controller adjusts the pulse width such that the output is brought back to constant value. Closed loop system uses a semiconverter to maintain constant amplitude at the output. The output of the rectifier in the closed loop system is shown in Fig.4.f. The Ac voltage in the closed loop system is as shown in Fig.4.g. It can be seen that the closed loop maintains constant voltage.

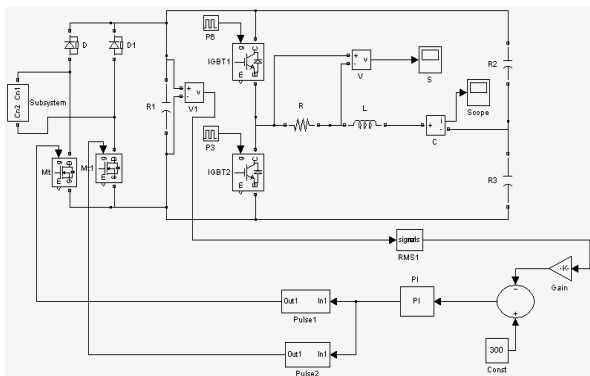

Fig.4.e. Closed loop Circuit diagram

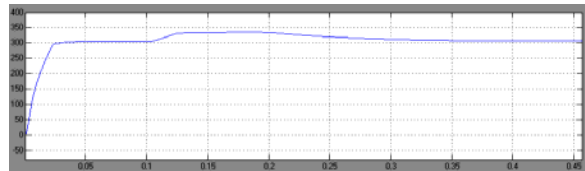

Fig.4.f. Rectifier output voltage.

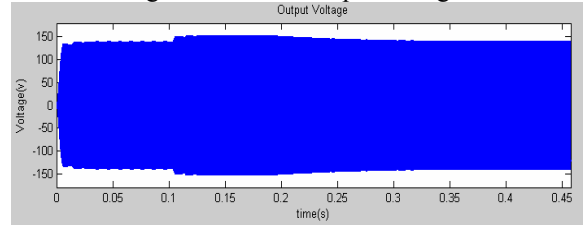

Fig.4.g. Output Voltage

Similarly Class E inverter circuit is shown in Fig.5a. DC input voltage is shown in Fig .5b. Driving pulses are shown in Fig 4c. The pulse given to the second switch is shifted by 180 Degree with respect to the pulse of Switch 1.Voltage across the inverter is shown in Fig. d. It can be seen that the output voltage is almost sine wave.

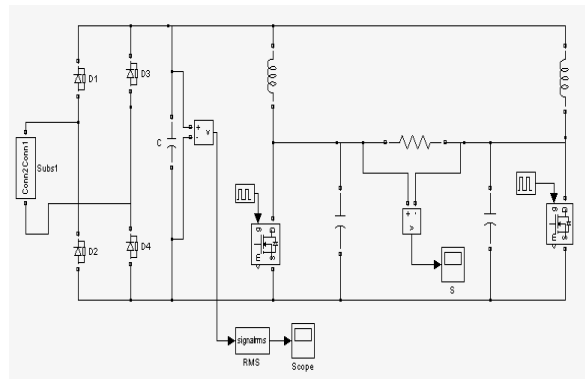

Fig.5.a. Matlab circuit of class E Inverter

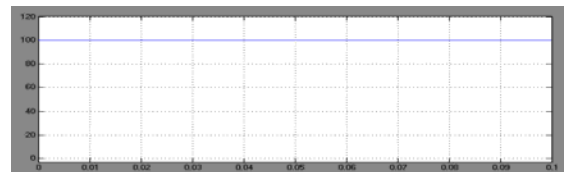

Fig.5.b. DC input voltage

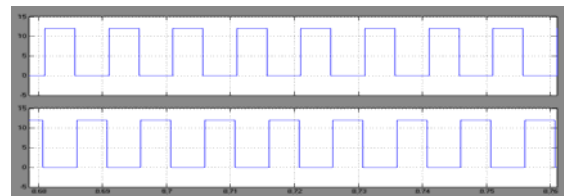

Fig.5.c. Driving pulses

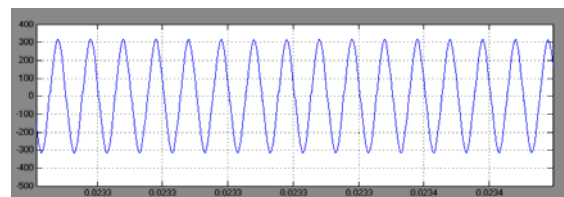

Fig.5.d. Output voltage

Simulink model of open loop system is shown in Fig. 6a. The low frequency AC input voltage is converted into DC using an uncontrolled rectifier.

The output of the rectifier is converted into high frequency AC using Class E inverter. A step disturbance is applied at the input as shown in Fig. 6b.

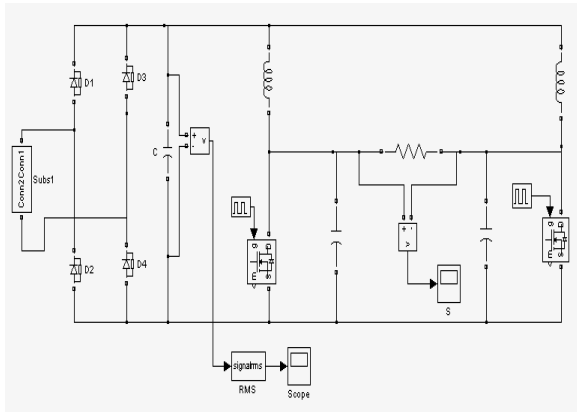

Fig.6.a. Open loop circuit model

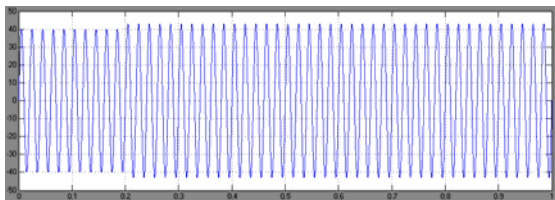

Fig.6.b Input voltage

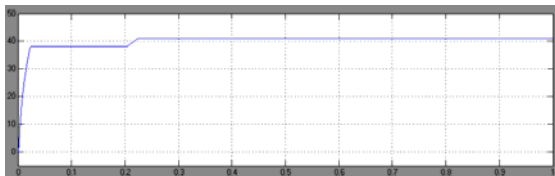

Fig.6.c Rectifier voltage



Fig.6.d Inverter output voltage

The output of rectifier is shown in Fig .6c. The Ac output voltage is shown in Fig .6d. It can be seen that the amplitude of output increases when there is a disturbance at the input.

The closed loop circuit model is shown in Fig. 6.e. The output is sensed and it is compared with the reference voltage.

The error is given to a PI controller, the output of PI controller adjusts the pulse width to bring the voltage to the set value. The rectifier output is shown in Fig. 6f. AC output voltage is shown in Fig 6.g.

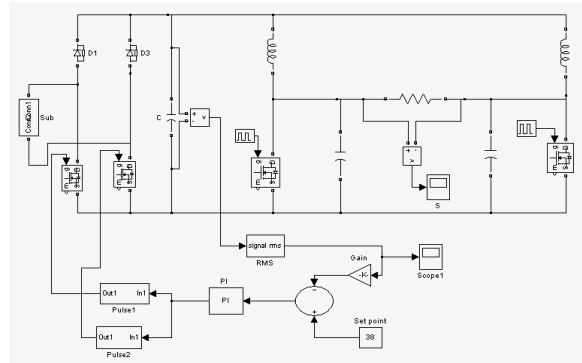

Fig.6.e. Closed loop Circuit diagram

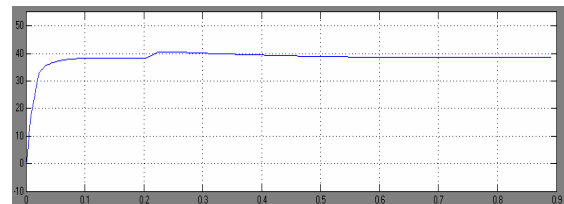

Fig.6.f. Rectifier Output Voltage

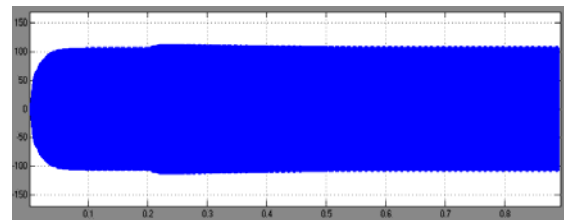

Fig.6.g. Inverter Output Voltage

Comparisons of Input Voltage vs Output Voltage & Input Voltage vs Output Power are as shown in Fig. 7.a. & Fig. 7.b. respectively.

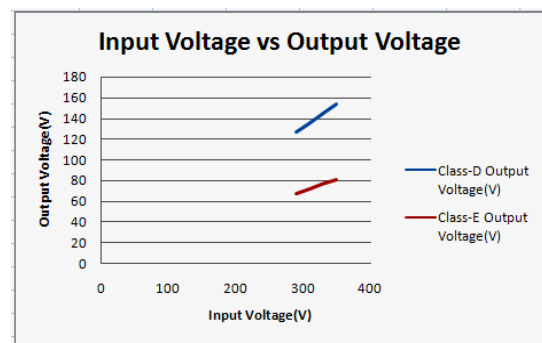

Fig.7.a. Input Voltage vs Output Voltage

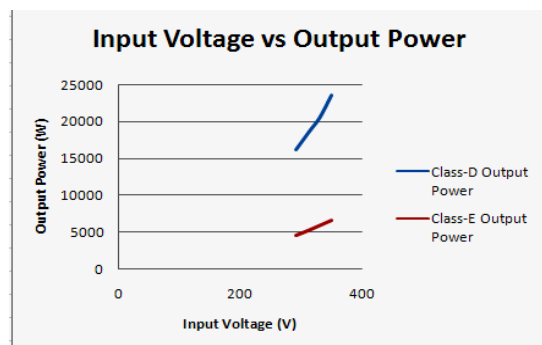

Fig.7.b. Input Voltage vs Output power

4. CONCLUSIONS

A Class D/Class E inverter fed induction heater is studied and simulated using Matlab Simulink. This research dealt with the comparison between ClassD/ClassE topology both in circuit and performance wise. The comparisons are primarily done with regard to switching losses and switching stresses as the important parameters for these two inverters. The comparisons of simulation results are presented. It is observed that the Class D inverter produces higher output voltage than Class E system. Class D inverter produces higher output power than Class E system. Also this class D system operates at high efficiency due to soft switching. This system has advantages like reduced volume, and faster response. Volume of L and C is reduced due to high frequency operation. Hardware is reduced since it uses only two switches. The simulation results are in line with predictions. This work deals with simulation studies. Hardware implementation is not in the scope of this work.

ACKNOWLEDGMENT

The authors are acknowledging the support given by Power Electronics division, in Bharath University, and Ganadipathy Tulsis Jain Engg College for conducting the simulation studies during July 2011 to August 2011.

References

- [1] B.Saha, S.K.Kwon, N.A.Ahmed, H.Omori, M.Nakaoka, "Commercial Frequency AC to High Frequency AC Converter With Boost-Active Clamp Bridge Single Stage ZVS-PWM Inverter," *IEEE Trans. on Power Electronics*, Vol.23, No.1, pp.412-418, January 2008.
- [2] Jafar, J.J., and Fernandes, B.G.: 'A new quasi-resonant DC-link PWM inverter using single switch for soft switching', *IEEE Trans. Power Electron.*, 2008, 17, p. 1010
- [3] J. T. Matysik, "A new method of integration control with instantaneous current monitoring for class D series-resonant converter," *IEEE Trans. Ind. Electron.*, vol. 53, no. 5, pp. 1564–1576, Oct. 2006.
- [4] D.-Y. Jung and J.-Y. Park, "Electronic ballast with constant power output controller for 250W MH lamp," *J. Electr. Eng. Technol.*, vol. 1, no. 3, pp. 332–337, 2006.
- [5] H. Kifune, Y. Hatanaka, and M. Nakaoka, "Cost effective phase shifted pulse modulation soft switching high frequency inverter for induction heating applications," *Proc. Inst. Elect. Eng.*, vol. 151, no. 1, pp. 19–25, Jan. 2008.
- [6] J. Acero, R. Alonso, J. M. Burdío, and L. A. Barragán, "Modeling of planar spiral inductors between two multilayer media for induction heating applications," *IEEE Trans. Magn.*, vol. 42, no. 11, pp. 3719–3729, Nov. 2009.
- [7] Y.Kawaguchi, E.Hiraki, T.Tanaka, M.Nakaoka, "Full bridge phase-shifted soft switching high-frequency inverter with boost PFC function for induction heating system" *Proceedings of European Conference on Power Electronics and Applications (EPE)*, pp.1-8, Sept., 2007.
- [8] S. W. Ma, H. Wong, and Y. O. Yam, "Optimal design of high output power Class-E amplifier," in *Proc. 4th IEEE Int. Caracas Conf. on Devices, Circuits and Systems*, ruba, Apr. 17–19, 2002, pp. P012-1–P012-5.
- [9] S. D.Kee, I. Aoki, A. Hajimiri, and D. Rutledge, "The Class-E/F family of ZVS switching amplifiers," *IEEE Trans. Microw. Theory Tech.*, vol. 51, no. 6,, Jun. 2003.
- [10] D. J. Kessler and M. K. Kazimierczuk, "Power losses and efficiency of Class-E power amplifier at any duty ratio," *IEEE Trans. Circuits Syst I, Reg. Papers*, vol. 51, no. 9, pp. 1675–1689, Sep. 2004.
- [11] D. J. Kessler and M. K. Kazimierczuk, "Power losses and efficiency of Class-E power amplifier at any duty ratio," *IEEE Trans. Circuits Syst I, Reg. Papers*, vol. 51, no. 9, pp. 1675–1689, Sep. 2004.
- [12] W. A. Davis and K. K. Agarwal, *Radio Frequency Circuit Design*. New York: Wiley, 2001, ch. 6.
- [13] S. C.Wong and C. K. Tse, "Design of symmetrical Class-E power amplifiers for very low harmonic-content applications," *IEEE Trans. Circuits Syst I, Reg. Papers*, vol. 52, no. 8, pp. 1684–1690, Aug. 2005.
- [14] V. Yousefzadeh, N. Wang, Z. Popovic', and D. Maksimovic', "A digitally controlled DC/DC converter for an RF power amplifier," *EETrans. Power Electron*, vol. 21, pp. 164–172, Jan. 2006
- [15] T. Suetsugu and M. K. Kazimierczuk, "Design procedure of Class-Amplifier for off-nominal operation at 50% duty ration," *IEEE Trans.Circuits Syst I, Reg. Papers*, vol. 53, no. 7, pp. 1468–1476, Jul. 2006.
- [16] S. Pajic', N. Wang, P. M. Watson, T. K. Quach, and Z. Popovic', "X-band two-stage high-efficiency switched-mode power amplifiers," *IEEE Trans. Microw. Theory Tech.*, vol. 53, no. 9, pp. 2899–2907, Sep. 2005.
- [17] B.Saha, K.Y. Suh, S.K. Kwon, and M.Nakaoka, "Selective dual duty cycle controlled high frequency inverter using resonant capacitor in parallel with an auxiliary reverse blocking switch," *J.Power Electron.*, vol.7, no.2, pp118-123, Apr. 2007.
- [18] Kifune, H.; Hatanaka, Y.; Nakaoka, M, Cost effective phase shifted pulse modulation soft switching high frequency inverter for induction heating applications. *IEE Proc.-Electr. Power Appl.*, Vol. 151, No. 1, , pp. 19-25, January 2004

- [19]. S. C.Wong and C. K. Tse, "Design of symmetrical Class-E power amplifiers for very low harmonic-content applications," IEEE Trans. Circuits Syst I, Reg. Papers, vol. 52, no. 8, pp. 1684–1690, Aug. 2005.

About Authors



S.Arumugam has obtained his B.E degree from Bangalore University, Bangalore in the year 1999. He obtained his M.E degree from Sathyabama University, Chennai in the year 2005. He is presently a research scholar at

Bharath University, Chennai. He is working in the area of Resonant inverter fed Induction Heating. He has published more than 10 international journals. Presently he is working as a Professor in Electrical and Electronics Engg department at Ganadipathy Tulsis jain Engineering college, Vellore, Tamilnadu. He has published books on Basic Electrical Engg and Electrical machines.



S.Ramareddy is Professor of Electrical Department, Jerusalem Engineering College, Chennai. He obtained his D.E.E from S.M.V.M Polytechnic, Tanuku, A.P. A.M.I.E in Electrical Engg from institution of Engineers (India), M.E in Power

System from Anna University. He received Ph.D degree in the area of Resonant Converters from College of Engineering, Anna University, Chennai. He has published over 20 Technical papers in National and International Conference proceeding/Journals. He has secured A.M.I.E Institution Gold medal for obtaining higher marks. He has secured AIMO best project award. He has worked in Tata Consulting Engineers, Bangalore and Anna University, Chennai. His research interest is in the area of resonant converter, VLSI and Solid State drives. He is a life member of Institution of Engineers (India), Indian Society for India and Society of Power Engineers. He is a fellow of Institution of Electronics and telecommunication Engineers (India). He has published books on Power Electronics and Solid State circuits.